

PUMP/TANK METERING SYSTEMS

FPUTS1500 Series

Starts at

\$493



- ✓ Single Intake and Discharge Check Valve Pump Design
- ✓ Quick-Adjusting Feed Mechanism
- ✓ Polyethylene Tank with UV Inhibitor
- ✓ 7-, 15-, or 30-Gallon Tank Sizes
- ✓ 100% Duty Cycle

The FPUTS1500 Series metering systems are efficient and self-contained, consisting of a sturdy polyethylene tank and an injector pump. They are available in 7-, 15-, or 30-gallon capacities. The tank is rectangular for convenient storage and features a multi-position opening that lets the user open, close, or vent the lid. Features of the injector pump include a heavy-duty cartridge valve pumphead of injection-molded polypropylene, outfitted with PVDF fittings, ceramic ball checks, FKM O-ring seals, and Hastelloy C valve springs; a durable PTFE/EPDM diaphragm; attractive weather-resistant black Valox® housing; a ball bearing gear motor; and a flow indicator.

An optional built-in electronic percentage timer allows even more precise control. With this timer, the user can adjust the feed or the diaphragm strokes.

SPECIFICATIONS

Output Accuracy: ±10% of max (water)

Max Pressure: 8.6 bar (125 psig)

Max Fluid Temperature: 54°C (130°F)

Max Viscosity: 1000 centipoise

Max Suction Lift: 3 m (10') water

Turndown Ratio: 27:1

Tank Only

Model No.	Price	Capacity
FTNK-7	\$186	7 gallons
FTNK-15	298	15 gallons
FTNK-30	410	30 gallons

Recommended Reference Book:
Chemical Engineering Fluid Mechanics,
FW-0107, \$78.

See Section Y for Additional Books



FPUTS1503-15,
\$588, shown
smaller than
actual size.



Comes with handy flow indicator. Additional pump accessories shown in this section.

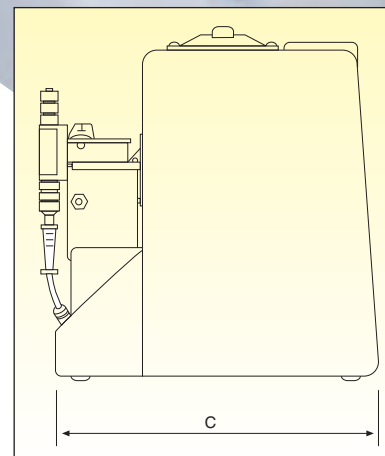
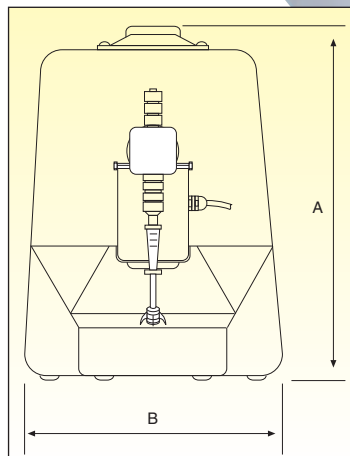

Dimensions

Tank Model	FTNK-7	FTNK-15	FTNK-30
Weight, kg (lb)	8.6 (19)	12.2 (27)	15.9 (35)
Capacity, gallons	7	15	30
Height (A), mm (in)	445 (17.5)	559 (22)	689 (27)
Width (B), mm (in)	305 (12)	394 (15.5)	508 (20)
Depth (C), mm (in)	406 (16)	495 (19.5)	610 (24)

MOST POPULAR MODELS HIGHLIGHTED!

To Order (Specify Model Number)

7-Gal. Capacity		15-Gal. Capacity		30-Gal. Capacity		Strokes /min	Max GPD	Max mL/min
Model No.	Price	Model No.	Price	Model No.	Price			
FPUTS1501	\$504	FPUTS1501-15	\$599	FPUTS1501-30	\$693	14	3.4	8.9
FPUTS1503	493	FPUTS1503-15	588	FPUTS1503-30	682	30	8.3	21.8
FPUTS1505	493	FPUTS1505-15	588	FPUTS1505-30	682	45	26.6	70
FPUTS1507	493	FPUTS1507-15	588	FPUTS1507-30	682	60	16.3	42
FPUTS1509	493	FPUTS1509-15	588	FPUTS1509-30	682	125	68.4	180

Comes complete with FPU DT1500, 115 V/60 Hz pump and operator's manual, 3/8" OD PVC suction tube foot valve and strainer suction tube weight, suction tubing, discharge tubing and injection fitting with internal backflow check valve and mounting hardware.

For units with stroke and time interval adjustment, add suffix "-D" to model number and \$47 to price (not available on FPUTS1501 pumps).

Ordering Examples: FPUTS1505-15-D, 15-gallon system with 45 strokes/min, 26.6 GPD, 70 mL/min capacity and optional stroke and time interval adjustment, \$588 + 47 = \$635.

FPUTS1507-30, 30-gallon system with 60 strokes/min, 16.3 GPD, 42 mL/min capacity, \$682.

omega.co.uk[®]

Your One-Stop Source for Process Measurement and Control!

Freephone 0800 488 488 | International +44(0) 161 777 6622 | Fax +44(0) 161 777 6622 | Sales@omega.co.uk

www.omega.co.uk



UNITED STATES

www.omega.com

1-800-TC-OMEGA
Stamford, CT.

UNITED KINGDOM

www.omega.co.uk

Manchester, England
0800-488-488
+44-(0)161-777-6611

CANADA

www.omega.ca

Laval(Quebec)
1-800-TC-OMEGA

FRANCE

www.omega.fr

0800-466-342

GERMANY

www.omega.de

Deckenfronn, Germany
0800-8266342

BENELUX

www.omega.nl

0800-099-33-44



More than 100,000 Products Available!

• Temperature

Calibrators, Connectors, General Test and Measurement Instruments, Handheld Instruments for Temperature Measurement, Ice Point References, Indicating Labels, Crayons, Cements and Lacquers, Infrared Temperature Measurement Instruments, Recorders, Relative Humidity Measurement Instruments, PT100 Probes, PT100 Elements, Temperature & Process Meters, Timers and Counters, Temperature and Process Controllers and Power Switching Devices, Thermistor Elements, Probes and Assemblies, Thermocouples, Thermowells and Head and Well Assemblies, Transmitters, Thermocouple Wire, RTD Probes

• Flow and Level

Air Velocity Indicators, Doppler Flowmeters, Level Measurement, Magnetic Flowmeters, Mass Flowmeters, Pitot Tubes, Pumps, Rotameters, Turbine and Paddle Wheel Flowmeters, Ultrasonic Flowmeters, Valves, Variable Area Flowmeters, Vortex Shedding Flowmeters

• pH and Conductivity

Conductivity Instrumentation, Dissolved Oxygen Instrumentation, Environmental Instrumentation, pH Electrodes and Instruments, Water and Soil Analysis Instrumentation

• Data Acquisition

Communication Products and Converters, Data Acquisition and Analysis Software, Data Loggers Plug-in Cards, Signal Conditioners, USB, RS232, RS485, Ethernet and Parallel Port Data Acquisition Systems, Wireless Transmitters and Receivers

• Pressure, Strain and Force

Displacement Transducers, Dynamic Measurement Force Sensors, Instrumentation for Pressure and Strain Measurements, Load Cells, Pressure Gauges, Pressure Reference Section, Pressure Switches, Pressure Transducers, Proximity Transducers, Regulators, Pressure Transmitters, Strain Gauges, Torque Transducers, Valves

• Heaters

Band Heaters, Cartridge Heaters, Circulation Heaters, Comfort Heaters, Controllers, Meters and Switching Devices, Flexible Heaters, General Test and Measurement Instruments, Heater Hook-up Wire, Heating Cable Systems, Immersion Heaters, Process Air and Duct, Heaters, Radiant Heaters, Strip Heaters, Tubular Heaters