

SELF-ADJUSTING WEIGH ASSEMBLIES WITH LC501 SERIES LOAD CELL INCLUDED



TWA5 (Nickel-Plated Carbon Steel) TWA6 (Stainless Steel)

0-100 lb to 0-20,000 lb
0-45 kg to 0-9074 kg

1 Newton = 0.2248 lb
1 daNewton = 10 Newtons
1 lb = 454 g
1 t = 1000 kg = 2204 lb

TWA5-750, \$560, includes LC501-750 load cell, shown smaller than actual size. See page F-62 for details on LC501 load cells.

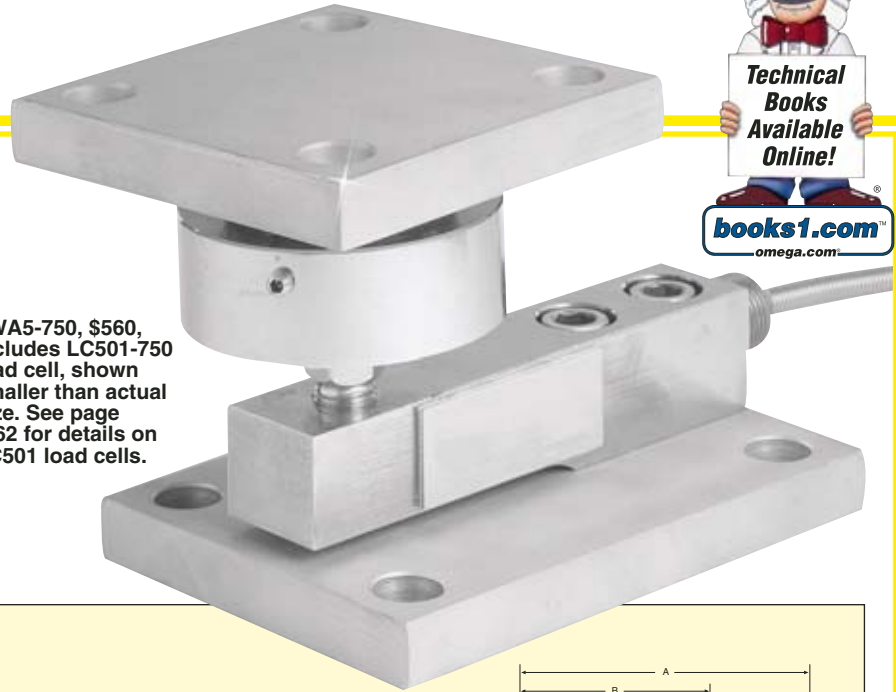

Starts at
\$560



- ✓ Heavy-Duty Design
- ✓ For Tank and Bin Weighing
- ✓ Corrosion-Resistant Material
- ✓ Self-Adjusting for Accurate Measurements

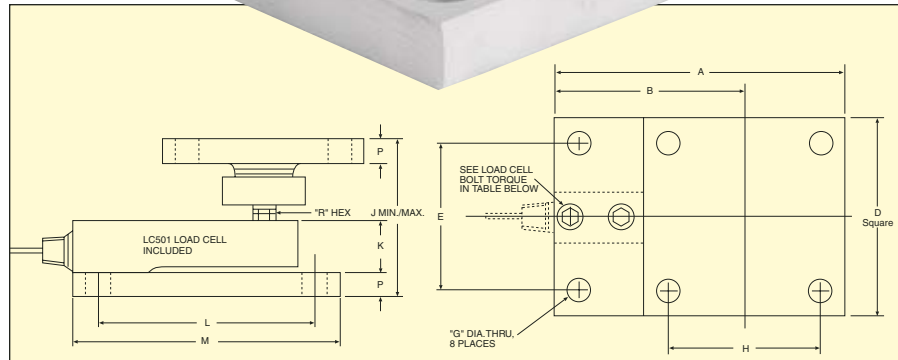

Dimensions: mm (in)

CAPACITY lb (N)	A	B	D	E	G	H	J	K	L	M	P	R	TORQUE ft-lb (N-m)
≤750 (≤3 K)	146 (5.75)	102 (4.00)	89 (3.50)	64 (2.50)	13 (0.53)	64 (2.50)	95/102 (3.75/4.00)	1.00 (25)	102 (4.00)	127 (5.00)	13 (0.50)	14 (0.56)	22 (30)
1 K-5 K (5 K-20 K)	222 (8.75)	146 (5.75)	152 (6.00)	114 (4.50)	17 (0.68)	114 (4.50)	121/127 (4.75/5.00)	1.50 (38)	165 (6.50)	203 (8.00)	19 (0.75)	14 (0.56)	56 (76)
10 K (40 K)	248 (9.75)	171 (6.75)	152 (6.00)	114 (4.50)	17 (0.68)	114 (4.50)	127/133 (5.00/5.25)	1.50 (38)	165 (6.50)	203 (8.00)	19 (0.75)	22 (0.88)	180 (245)
20 K (80 K)	311 (12.25)	216 (8.50)	191 (7.50)	140 (5.50)	21 (0.81)	140 (5.50)	184/191 (7.25/7.50)	2.50 (64)	203 (8.00)	254 (10.00)	25 (1.00)	29 (1.12)	180 (245)

MOST POPULAR MODELS HIGHLIGHTED!

To Order (Specify Model Number)

CAPACITY	WEIGHING ASSEMBLIES WITH LOAD CELL				REPLACEMENT LOAD CELL			
	lb	kg	CARBON STEEL	STAINLESS STEEL	MODEL NO.	PRICE		
100	45		TWA5-100	\$560	TWA6-100	\$735	LC501-100	\$340
200	91		TWA5-200	560	TWA6-200	735	LC501-200	340
500	227		TWA5-500	560	TWA6-500	735	LC501-500	340
750	341		TWA5-750	560	TWA6-750	735	LC501-750	340
1000	455		TWA5-1K	615	TWA6-1K	745	LC501-1K	350
2000	909		TWA5-2K	615	TWA6-2K	745	LC501-2K	350
3000	1361		TWA5-3K	615	TWA6-3K	745	LC501-3K	350
5000	2269		TWA5-5K	615	TWA6-5K	745	LC501-5K	350
10,000	4537		TWA5-10K	805	TWA6-10K	970	LC501-10K	695
20,000	9074		TWA5-20K	1055	TWA6-20K	1220	LC501-20K	695

SPECIFICATIONS

Non-Parallel Mounting:
Self-adjusting for surfaces up to 2°

Thermal Expansion:
Self-adjusting for up to ±1/8"

Height:
Adjustable per dimension "J"

Weight (Including Load Cell)

Range	lb (kg)
100 to 750	10 (4.5)
1000 to 5000	23 (10.5)
10,000	25 (11.5)
20,000	55 (25)

5-Point Calibration (in Compression):
0%, 50%, 100%, 50%, 0%

See pages F-14 to F-16 for summing J-boxes.

ACCESSORY

MODEL NO.	PRICE	DESCRIPTION
OP-17	\$15	Reference Book: Measure for Measure

Note: Load cell will be installed into the TWA module. Load cell has 5-point, NIST-traceable calibration.

Ordering Examples: TWA6-5K, 5000 lb weighing assembly in stainless steel with LC501-5K load cell included, \$745. TWA5-750, 750 lb weighing assembly in carbon steel with LC501-750 load cell included, \$560.

omega.co.uk[®]

Your One-Stop Source for Process Measurement and Control!

Freephone 0800 488 488 | International +44(0) 161 777 6622 | Fax +44(0) 161 777 6622 | Sales@omega.co.uk

www.omega.co.uk



UNITED STATES

www.omega.com

1-800-TC-OMEGA
Stamford, CT.

UNITED KINGDOM

www.omega.co.uk

Manchester, England
0800-488-488
+44-(0)161-777-6611

CANADA

www.omega.ca

Laval(Quebec)
1-800-TC-OMEGA

FRANCE

www.omega.fr

0800-466-342

GERMANY

www.omega.de

Deckenfronn, Germany
0800-8266342

BENELUX

www.omega.nl

0800-099-33-44



More than 100,000 Products Available!

• Temperature

Calibrators, Connectors, General Test and Measurement Instruments, Handheld Instruments for Temperature Measurement, Ice Point References, Indicating Labels, Crayons, Cements and Lacquers, Infrared Temperature Measurement Instruments, Recorders, Relative Humidity Measurement Instruments, PT100 Probes, PT100 Elements, Temperature & Process Meters, Timers and Counters, Temperature and Process Controllers and Power Switching Devices, Thermistor Elements, Probes and Assemblies, Thermocouples, Thermowells and Head and Well Assemblies, Transmitters, Thermocouple Wire, RTD Probes

• Flow and Level

Air Velocity Indicators, Doppler Flowmeters, Level Measurement, Magnetic Flowmeters, Mass Flowmeters, Pitot Tubes, Pumps, Rotameters, Turbine and Paddle Wheel Flowmeters, Ultrasonic Flowmeters, Valves, Variable Area Flowmeters, Vortex Shedding Flowmeters

• pH and Conductivity

Conductivity Instrumentation, Dissolved Oxygen Instrumentation, Environmental Instrumentation, pH Electrodes and Instruments, Water and Soil Analysis Instrumentation

• Data Acquisition

Communication Products and Converters, Data Acquisition and Analysis Software, Data Loggers Plug-in Cards, Signal Conditioners, USB, RS232, RS485, Ethernet and Parallel Port Data Acquisition Systems, Wireless Transmitters and Receivers

• Pressure, Strain and Force

Displacement Transducers, Dynamic Measurement Force Sensors, Instrumentation for Pressure and Strain Measurements, Load Cells, Pressure Gauges, Pressure Reference Section, Pressure Switches, Pressure Transducers, Proximity Transducers, Regulators, Pressure Transmitters, Strain Gauges, Torque Transducers, Valves

• Heaters

Band Heaters, Cartridge Heaters, Circulation Heaters, Comfort Heaters, Controllers, Meters and Switching Devices, Flexible Heaters, General Test and Measurement Instruments, Heater Hook-up Wire, Heating Cable Systems, Immersion Heaters, Process Air and Duct, Heaters, Radiant Heaters, Strip Heaters, Tubular Heaters