

# OMB-DBK17

## 4-Channel Simultaneous Sample and Hold Card for Use with the OMB-DAQBOARD-2000 Series and OMB-LOGBOOK

Model OMB-DBK17

**\$629**

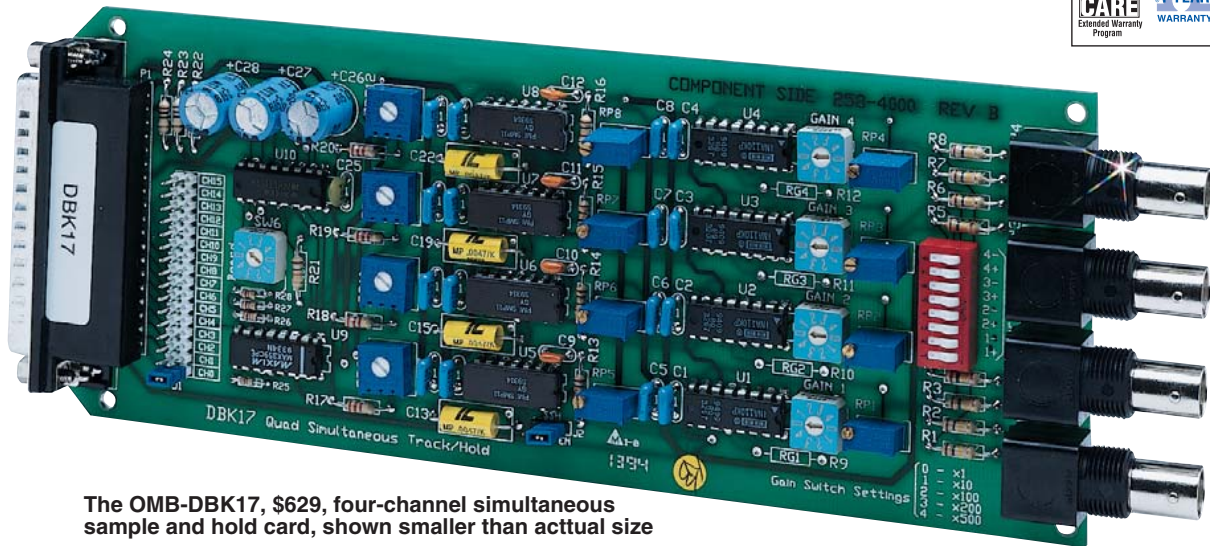

The OMB-DBK17, \$629, four-channel simultaneous sample and hold card, shown smaller than actual size

- **Separate Instrumentation Amplifier & Input Stage for Each Channel**
- **One System Accepts up to 64 OMB-DBK17 Cards for a Total of 256 Simultaneously Sampled Inputs**

The OMB-DBK17 simultaneous sample and hold card allows OMEGA's OMB-LOGBOOK and OMB-DAQBOARD-2000 Series data acquisition systems to capture multiple input channels concurrently in order to eliminate channel-to-channel time skewing. Each OMB-DBK17 provides four channels of differential voltage input to an OMB-LOGBOOK or OMB-DAQBOARD-2000 Series. The sixteen analog input channels of the above data acquisition systems can each accept four OMB-DBK17 cards, for a total of 256 analog input channels with simultaneous sampling. When multiple OMB-DBK17 cards are in use, all channels on all cards are sampled at the same instant.

Each of the OMB-DBK17's four channels features an instrumentation amplifier with switch-selectable gains of x1, 10, 100, 200, and 500.

Each channel is also equipped with a location for a user-selected gain resistor, allowing you to select a custom gain up to x500. Each of the instrumentation amplifier input stages is followed by separate sample-and-hold stages whose outputs are connected to an output multiplexer stage. You can connect up to four OMB-DBK17's to one analog input channel on an OMB-LOGBOOK or OMB-DAQBOARD-2000 Series.

The OMB-DBK17 is equipped with BNC input connectors. Its differential inputs are equipped with switchable 100 K bias resistors referenced to analog common.

### Specifications

**Connector:** DB37 male, mates with P1 pinout on the OMB-LOGBOOK, OMB-DAQBOARD-2000 Series; BNC connectors provided for signal inputs

**Number of Channels:** 4

**Input Type:** Differential

**Voltage Input Ranges:**

- 0 to ±5 Vdc
- 0 to ±500 mVdc
- 0 to ±25 mVdc
- 0 to ±10 mVdc

### For Custom Gains:

$$R_{\text{user}} = \frac{40,000}{\text{Gain}-1} - 80 \text{ (Ohms)}$$

### Input Amplifier Slew Rate:

12 V/μs min

### Acquisition Time:

0.6 μs (10 V excursion to 0.1%);  
0.7 μs (10 V excursion to 0.01%)

### Channel-to-Channel Aperture

**Uncertainty:** 50 ns

### Output Droop Rate:

0.1 μV/μs

**Input Gains:** x1, 10, 100, 200, 500,

and user determined up to 500

### Input Offset Voltage:

[500 + 5000/G] μV max (nullable)

### Input Offset Drift:

[±5 + 100/G] μV/°C max

### Input Bias Current:

100 pA max

### Input Offset Current:

50 pA max

### Input Impedance:

5 x 10<sup>12</sup> Ohms

parallel with 6 pF

### Switchable Bias Resistors:

100 K each to analog common

### Gain Errors:

x1 0.04% max

x10 0.1% max

x100 0.2% max

x200 0.4% max

x500 1.0% max

**AVAILABLE FOR FAST DELIVERY!**

To Order (Specify Model Number)		
Model Number	Price	Description
OMB-DBK17	\$629	4-Channel Simultaneous Sample and Hold Card

Ordering Example: OMB-DBK17 is a 4-channel simultaneous sample and hold card, \$629.

# High-Performance PCI-Based Data Acquisition Boards

## OMB-DAQBOARD-2000 Series

Starts at  
**\$689**

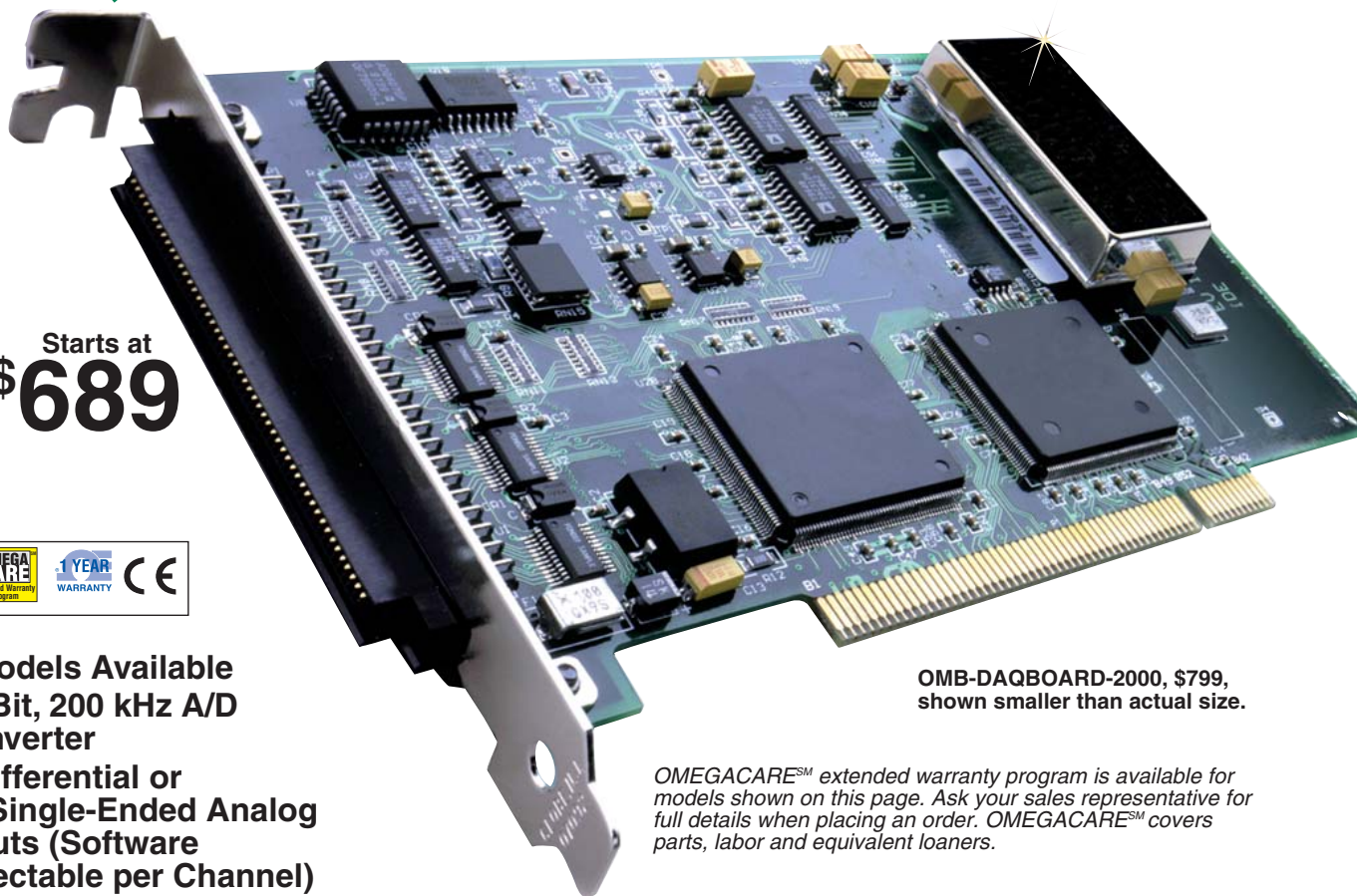

OMB-DAQBOARD-2000, \$799, shown smaller than actual size.

*OMEGACARE<sup>SM</sup> extended warranty program is available for models shown on this page. Ask your sales representative for full details when placing an order. OMEGACARE<sup>SM</sup> covers parts, labor and equivalent loaners.*

- ✓ 5 Models Available
- ✓ 16-Bit, 200 kHz A/D Converter
- ✓ 8 Differential or 16 Single-Ended Analog Inputs (Software Selectable per Channel)
- ✓ Expandable Up to 256 Analog Input Channels, While Maintaining 200 kHz (5  $\mu$ s per Channel) Scan Rate
- ✓ Up to 4 Boards Can be Installed into One PC for Up to 1024 Analog Input Channels
- ✓ 100% Digital Calibration
- ✓ 512-Location Channel/Gain FIFO, Capable of Scanning All Channels, Including 256 Analog Expansion Channels and Digital/Counter Channels, at 5  $\mu$ s per Channel
- ✓ DMA Bus Mastering for Synchronous Analog I/O, Digital I/O, and Counter Inputs

- ✓ Trigger Modes Include Analog, Digital, and Software, with <5  $\mu$ s Latency
- ✓ Virtually Infinite Pre-Trigger Buffer
- ✓ Up to Four 16-Bit, 100 kHz Analog Outputs with Infinite Continuous Waveform Output Capability
- ✓ 40 Digital I/O Lines, Can be Scanned Synchronously or Asynchronously with Analog Inputs
- ✓ Digital I/O is Expandable Up to 272 Lines, Including Optional Isolation and Relay Closure

- ✓ 4 Counter/Pulse Input Channels Can be Scanned Synchronously or Asynchronously with Analog Inputs
- ✓ 2 Timer/Pulse Output Channels
- ✓ Signal Conditioning and Expansion Options for Thermocouples, Strain Gages, Accelerometers, Isolation, and RTDs—Over 30 Options in All
- ✓ Includes DaqView Windows Software; DaqX API Library, Drivers for Visual Basic, C++, and Delphi for Windows 95 and Higher; C++ for Linux; DASyLab, TestPoint, and LabVIEW

**OMB-DAQBOARD-2000 Series Selection Chart**

Feature	OMB-DAQBOARD Models I/O				
	2001	2000	2005	2004	2002
Analog Inputs (P1) (16 bit/200 kHz)	16	16	16	-	-
Analog Outputs (P3) 16 bit/100 kHz)	4	2	-	4	-
Digital I/O (P2, P3)	40	40	40	40	40
Freq./pulse I/O (P3)	6	6	6	6	6-

The OMB-DAQBOARD-2000 Series sets the price/performance benchmark for high-speed, multifunction plug-and-play data acquisition for PCI bus computers. The hardware design offers all the features normally found on significantly more expensive boards, including 16-bit, 200 kHz A/D; 100% digital calibration; bus mastering, two or four 16-bit, 100 kHz A/D converters; 40 digital I/O lines; 4 counters; and 2 timers.

The OMB-DAQBOARD-2000 Series is supported by a growing family of over 30 signal conditioning and expansion options, offering signal conditioning for thermocouples, RTDs, accelerometers, isolation, high voltage, strain gages, and much more. Up to 528 channels of analog and digital I/O can be accessed with one OMB-DAQBOARD-2000, while maintaining the 5  $\mu$ s per channel update rate. Up to 4 OMB-DAQBOARD-2000s can be installed into one PC.

The OMB-DAQBOARD-2000 has more extensive software capabilities than most other boards, with comprehensive drivers for nearly every programming environment supported by Windows 95 and higher. Included in this list are Visual Basic, C++, Delphi, TestPoint, LabVIEW, and DASyLab, and C++ for Linux. Also included is a suite of DaqView software options for setup, acquisition, display, and analysis of acquired data—no programming required.

### Synchronous I/O for High-Speed Applications

The OMB-DAQBOARD-2000 Series sets a new standard with its ability to make analog measurements, read digital inputs, and read counter inputs, while synchronously generating up to 4 analog outputs and/or a 16-bit digital pattern output. Most other boards require CPU interaction to access I/O other than analog input, making it impossible to generate time-critical analog waveforms or digital patterns. With the OMB-DAQBOARD-2000 Series, the true power of PCI-based PCs can be unleashed.

The same synchronous features of the OMB-DAQBOARD-2000 extend to its family of OMB-DBK signal conditioning and expansion options. Up to 256 analog input channels and 272 (P2 only) digital I/O channels can also be accessed synchronously to one another, with precise and deterministic channel-to-channel timing. Up to 4 OMB-DAQBOARD-2000s can be installed in one PC, quadrupling the channel capacity to over 1000 analog input channels, 1000 digital I/O channels, and 16 high-speed analog output channels.

### Signal I/O

One 100-pin connector on the OMB-DAQBOARD-2000 Series provides access to all the input and output signals. Unlike other multifunction boards that require multiple PC slots, the OMB-DAQBOARD-2000 Series accommodates all I/O using one cable and has only one PCI slot.

The 100-pin OMB-DAQBOARD/2000 Series I/O connector, P4, is logically divided into 3 subports: P1, P2, and

P3. P1, the analog input port, contains all of the analog input channels, as well as the sequencer control signals for accessing external analog input options. All analog expansion options attach to the P1 port. P2, the general purpose digital I/O port, can be used directly to control and monitor 24 digital I/O lines. P2 can also function as the digital I/O expansion port, whereby the 24 lines are exclusively used to control external digital OMB-DBK expansion options, for up to 256 lines of digital input or output. P3 contains an additional 16-bit digital I/O port, as well as the counter inputs, timer outputs, and analog outputs. Several options are available to provide easy user access to all of the I/O signals on P4.

### Analog Input (P1)

The OMB-DAQBOARD-2000 Series has a 16-bit, 200 kHz A/D coupled with 16 single-ended or 8 differential analog inputs. Thirteen software-programmable ranges provide inputs from  $\pm 10$  V to  $\pm 156$  mV full scale. Each channel can be software configured for a different range, as well as for single-ended or differential and unipolar or bipolar inputs. Beyond the 16 built-in analog inputs, the user can expand the OMB-DAQBOARD-2000 Series up to 256 analog inputs using external OMB-DBK signal conditioning and expansion options. As with the on-board channels, expansion channels are scanned at the same 5  $\mu$ s/channel rate (200 kHz), and most are software programmable for range. There is no speed penalty for scanning expansion channels versus built-in channels. The OMB-DBK expansion options offer a wide variety of signal measurements, including thermocouples, RTDs, strain gages, accelerometers, high voltage, isolation, current, and much more.

## Scanning

The OMB-DAQBOARD-2000 Series has an on-board scan sequencer that permits the user to select any combination of up to 512 channel/range combinations. The sequencer scans all channels contained in the sequence at the fastest rate of 5  $\mu$ s/channel, thereby minimizing the time-skew from channel-to-channel. The user can also set the time between scan groups, from 0 to 6 hours. In addition to scanning analog inputs, the sequencer can scan digital inputs and counter inputs.

## Channel-Scanning Flexibility

The OMB-DAQBOARD-2000 Series offers a 512-location scan sequencer that allows the user to select each channel and associated input amplifier gain at random. The sequencer circuitry circumvents a major limitation encountered with many plug-in data acquisition boards—a drastic reduction in the scan rate for external expansion channels. All OMB-DAQBOARD-2000 Series channels, including the 528 potential expansion channels, are scanned at 200 kHz (5  $\mu$ s/channel). In addition, the digital and frequency inputs can be scanned by using the same scan sequence employed for analog inputs, enabling the time correlation of acquired digital data to acquired analog data. The OMB-DAQBOARD-2000 Series permits each scan group, which can contain up to 512 channel/gain combinations, to be repeated immediately or at a programmable interval of up to 6 hours. Within each scan group, consecutive channels are measured at a fixed 5  $\mu$ s/channel rate.

## Bus Mastering DMA

The OMB-DAQBOARD-2000 Series supports bus mastering DMA, which allows analog and digital/counter input data, as well as analog and digital output data, to flow between the PC and the OMB-DAQBOARD-2000 Series without consuming valuable CPU time.

The driver supplied with the OMB-DAQBOARD-2000, as well as all other third-party software support such as TestPoint, LabVIEW, and

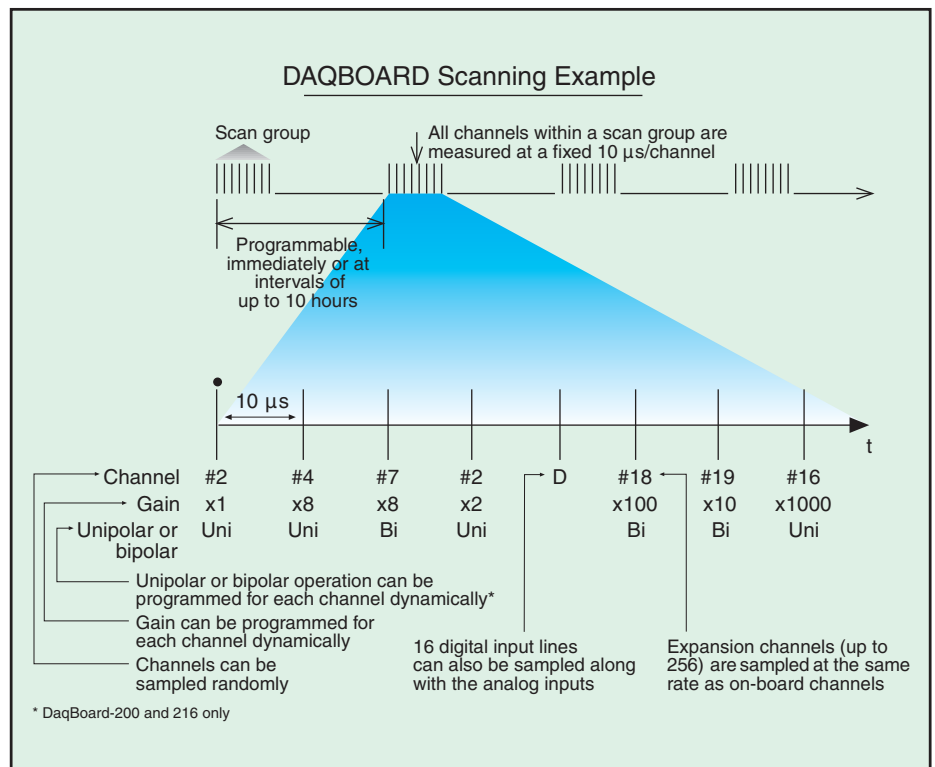

DASYLab, automatically use bus mastering DMA to efficiently conduct I/O from the PC to the OMB-DAQBOARD-2000.

## Triggering

Triggering can be the most critical aspect of a data acquisition application. The OMB-DAQBOARD-2000 Series supports a full complement of trigger modes to accommodate any measurement situation.

## Hardware Analog Triggering

Many data acquisition boards claim analog triggering, but rely on the PC to take readings and make a decision, which leads to uncertain and potentially long latencies. The OMB-DAQBOARD-2000 Series uses true analog triggering, whereby the trigger level programmed by the user sets an analog DAC, which is then compared in hardware to the analog input level on the selected channel. The result is analog trigger latency that is guaranteed to be less than 5  $\mu$ s, significantly shorter than that of most data acquisition boards.

Any analog channel can be selected as the trigger channel, including built-in or expansion channels. The

user can program both the trigger level and the edge (rising or falling).

## Digital and Pattern Triggering (P1)

A separate digital trigger input line is provided, allowing TTL-level triggering, again with latencies guaranteed to be less than 5  $\mu$ s. Both the logic levels (1 or 0) and the edge (rising or falling) can be programmed for the discrete digital trigger input.

## Software-Based Triggering

Software-based triggering differs from the modes described above because the readings— analog, digital, or counter—are interrogated by the PC to detect the trigger event, not in the hardware as described above. The advantage of this mode is to permit triggering based on more complex situations, such as on a specific temperature, which was derived from the acquisition of at least 2 analog measurements, plus the calculation of the measured temperature using linearization algorithms.

The OMB-DAQBOARD-2000 Series also supports digital pattern triggering, whereby the user can designate any of the digital input ports as the trigger port. The programmed digital pattern, including the ability to mask or ignore specific bits, is then compared to the actual input until a match is detected, after which the sequencer begins the scan sequence. Triggering can also be programmed to occur when one of the counters reaches, exceeds, or is within a programmed level. Any of the built-in counter/totalizer channels can be programmed as a trigger source. Normally software-based triggering results in long latencies from the time that a trigger condition is detected until the actual capturing of data commences. However, the OMB-DAQBOARD-2000 Series circumvents this undesirable phenomenon by use of pre-trigger data. Specifically, when software-based triggering is employed and the PC detects that a trigger condition has occurred (which may be thousands of readings later than the actual occurrence of the signal), the OMB-DAQBOARD-2000 driver automatically looks back to the location in memory where the actual trigger-causing measurement occurred. The acquired data that are presented to the user actually begin at the point where the trigger-causing measurement occurs. The latency in this mode is equal to one scan cycle.

### Stop Trigger

Any of the software trigger modes described above can also be used to stop an acquisition. Thus an acquisition can be programmed to begin on one event, such as a temperature level, and then can stop on another event, such as a digital pattern.

### Pre- and Post-Triggering Modes

6 modes of pre- and post-triggering are supported, providing a wide variety of options to accommodate any measurement requirement.

With pre-trigger, the user must employ software-based triggering to initiate an acquisition.

*No pre-trigger, post-trigger stop event.* This, the simplest of modes, acquires data upon receipt of the trigger, and stops acquiring upon receipt of the stop-trigger event.

*Fixed pre-trigger with post-trigger stop event.* In this mode, the user specifies the number of pre-trigger readings to be acquired, after which acquisition continues until a stop-trigger event occurs.

*No pre-trigger, infinite post-trigger.* No pre-trigger data are acquired in this mode. Instead, data are acquired beginning with the trigger event, and are terminated when the operator issues a command to halt the acquisition.

*Fixed pre-trigger with infinite post-trigger.* The user specifies the amount of pre-trigger data to acquire, after which the system continues to acquire data until the program issues a command to halt acquisition.

*Variable pre-trigger with post-trigger stop event (driver support only).* Unlike the previous pre-trigger modes, this mode does not have to satisfy the pre-trigger number of readings before recognizing the trigger event. Thus the number of pre-trigger readings acquired is variable and dependent on the time of the trigger event relative to the start. In this mode, data continue to be acquired until the stop-trigger event is detected.

*Variable pre-trigger with infinite post-trigger (driver support only).* This is similar to the mode described above, except that the acquisition is terminated upon receipt of a command from the program to halt the acquisition.

### Calibration

Every range on the OMB-DAQBOARD-2000 Series is calibrated from the factory using a digital calibration method. This method works by storing a correction factor for each range on the OMB-DAQBOARD-2000 Series at the time of calibration. Whenever a particular range is selected, the

appropriate calibration constant is automatically applied to a compensating DAC, thereby calibrating the specific range. The result is that readings generated by the A/D are already calibrated, and do not require additional processing. This is significantly better than other boards that merely adjust the readings in software after they are transferred to the PC. That method has the disadvantage of reducing the dynamic range of the A/D, and can adversely affect the speed by which the PC can obtain a calibrated reading. The OMB-DAQBOARD-2000 Series also has a USERCAL mode, whereby the user can adjust the calibration of the board in his or her system, without destroying the factory calibration supplied with the board. This is accomplished by having 2 distinct calibration tables in the OMB-DAQBOARD-2000 Series on-board EPROM, one that contains the factory calibration, and the other that is available for user calibration.

### Analog Output (P3) OMB-DAQBOARD-2000, -2001, and -2004 Only

Two or four 16-bit, 100 kHz analog output channels are built into the OMB DAQBOARD-2000 Series, with an output from -10 V to 10 V. These outputs are entirely separate from the D/As which are used to determine analog trigger level (some data acquisition board suppliers confusingly refer to trigger D/As as if they are available to the user). With bus mastering DMA, each D/A output can continuously output a waveform, which can be read from PC RAM or a file on the hard disk. In addition, a program can asynchronously output a value to either of the D/As for non-waveform applications, presuming that the D/A is not already being used in the waveform output mode.

Additional low-speed D/A channels can be added to the OMB-DAQBOARD-2000 through the use of the OMB-DBK2 analog output option card. When used to generate waveforms, the D/As can be clocked in several different modes. Each D/A can be separately selected to be clocked from one of the sources described below.

**Asynchronous Internal Clock** The on-board programmable clock can generate updates ranging from 1.5 Hz to 100 kHz, independent of any acquisition rate.

**Synchronous Internal Clock** The rate of analog output update can be synchronized to the acquisition rate derived from 100 kHz to once every 5.96 hours.

**Asynchronous External Clock** A user-supplied external input clock can be used to pace the D/A, entirely independent of analog inputs.

**Synchronous External Clock** A user-supplied external input clock can pace both the D/A and the analog input.

### Digital Pattern Generation (P3)

The OMB-DAQBOARD-2000 Series supports digital pattern generation via bus mastering DMA on the 16-bit high-speed digital I/O port. Like analog output, the digital pattern can be read from PC RAM or a file on the hard disk. Digital pattern generation is clocked in the same 4 modes as analog output (when digital pattern generation is used, one of the analog output channels is limited to asynchronous output mode).

### Digital Inputs and Outputs (P2, P3)

Forty TTL-level digital I/O lines are included in the OMB-DAQBOARD-2000 Series. They are divided into three 8-bit ports (P2) and one 16-bit port (P3).

The P2 ports can be programmed in 8-bit groups as either input or output. The 16-bit P3 port can be programmed as all inputs or all outputs. Ports programmed as

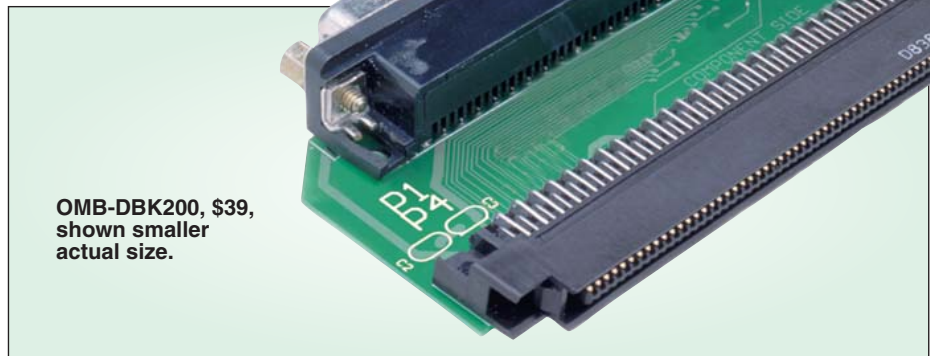

OMB-DBK200, \$39, shown smaller actual size.

inputs can be part of the scan group and scanned along with other analog and digital input channels, or can be asynchronously accessed via the PC at any time, including when a scanned acquisition is occurring. In addition, the P2 ports can be expanded up to 256 digital I/O lines using external OMB-DBK digital options. These options are available as TTL-level I/O, relay output, or optically isolated input and output. Whenever expansion digital I/O is attached to the OMB-DAQBOARD-2000 Series, the P2 I/O lines are no longer user programmable, but are used to communicate with the digital expansion options.

### Counter Inputs (P3)

Four 16-bit counters are built into the OMB-DAQBOARD-2000, each capable of counting up to 65,536 TTL-level transitions. Each of the 4 counters will accept frequency inputs up to 10 MHz. The counters can also be cascaded, allowing over 4 billion counts to be accumulated. As with all other inputs to the OMB-DAQBOARD-2000 Series, the counter inputs can be read asynchronously under program control, or synchronously as part of an analog and digital scan group.

### Timer Outputs (P3)

Two 16-bit timer outputs are built into the OMB-DAQBOARD-2000, each capable of generating different square waves with a programmable frequency range from 16 Hz to 1 MHz.

### Multiple OMB-DAQBOARD-2000s Per PC

All of the features described for the OMB-DAQBOARD-2000 can be replicated with up to

4 OMB-DAQBOARD-2000s installed in the same PC.

Each OMB-DAQBOARD-2000 has a serial number for identification, and a user-selected name can be assigned to each board for easy program documentation. Thus, with 4 boards installed along with OMB-DBK expansion options, over 1000 analog input channels and over 1000 digital I/O channels could be accessed from one PC. When multiple boards are installed, all boards can be operated synchronously. The OMB-DAQBOARD-2000 Series provides all I/O signals on one 100-pin connector. The following adaptor options make it easy for the user to attach signals and expansion options to the OMB-DAQBOARD-2000 Series.

### OMB-DBK200 Adaptor Board

Suitable exclusively for analog-signal expansion, the OMB-DBK200 adaptor board contains one 100-pin connector that connects to the OMB-DAQBOARD-2000 Series via the OMB-CA-195 cable, and one female DB37 connector that mates directly with the P1 port of any of the OMB-DBK analog signal conditioning and expansion options. This is the most convenient way to add analog expansion options if access to the OMB-DAQBOARD-2000 Series digital I/O or frequency signals is not required. Access to P1 analog signals is also possible via included female-mating solder-lug connectors or optional OMB-CA-37-x or OMB-CA-37-xT expansion cables.

## System Configuration Examples

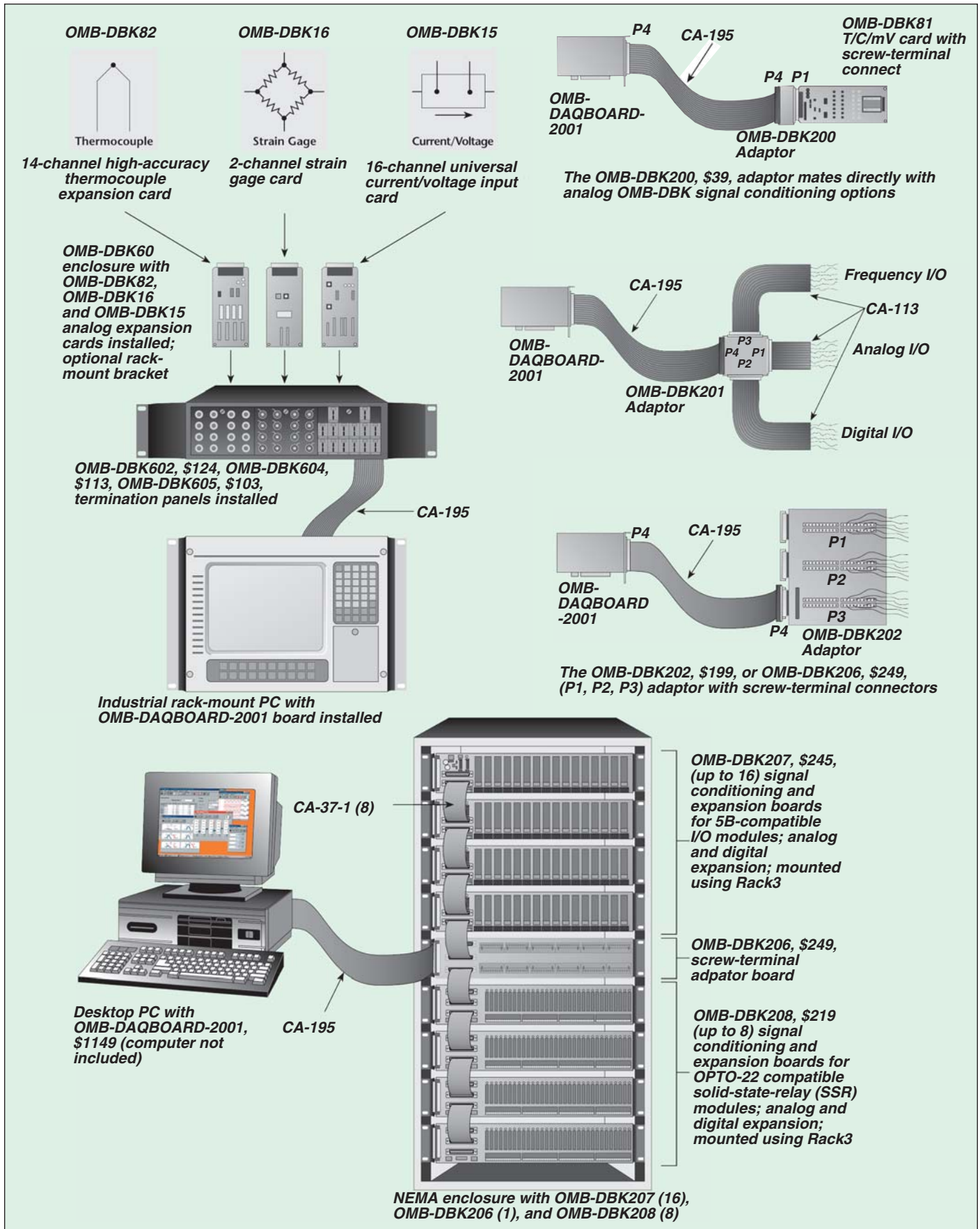



OMB-DBK207, \$249, shown smaller than actual size

Mounting holes in the OMB-DBK202 permit it to be easily screw-mounted into a user-provided enclosure. The OMB-DBK203 is identical to the OMB-DBK202, except that it is housed in a shielded metal enclosure, which easily mounts to other OMB-DBK signal conditioning and expansion modules. Optional fastener panels are available for attaching other OMB-DBK modules.

OMB-CA-195 cable, and each port (P1, P2, and P3) connects to DBK signal conditioning and expansion options via optional OMB-CA-37-x cable(s). The standard OMB-DBK206 can be panel mounted, but it also is DIN-rail mountable and rack-mountable with optional mounting kits.

### OMB-DBK207 and OMB-DBK207/CJC Multiplexing Isolated Analog Input Board

The OMB-DBK207 provides sockets for 16 channels of isolated analog input when populated with industry-standard 5B-style or compatible signal conditioning modules. Each channel features screw terminals and sockets for current conversion resistors (supplied with 5B current input modules). The OMB-DBK207/CJC features added cold-junction compensation per channel for thermocouple-based measurements.

Multiplexing is built-in, allowing up to 16 OMB-DBK207 boards to be directly connected to one OMB-DAQBOARD-2000 Series board for a total signal capacity of 256 isolated analog inputs. The 100-pin P4 connector on the OMB-DBK207 attaches directly to the OMB-DAQBOARD-2000 (via OMB-CA-195 cable). Two DB37 connectors permit daisy chaining to other OMB-DBK207 boards, and to any of the other OMB-DBK analog signal conditioning boards and modules. The OMB-DBK207/CJC and the OMB-DBK207 can be rack or snap-track mounted with optional mounting kits.



OMB-DBK202, \$199, and OMB-DBK203, \$299, shown smaller than actual size.

### OMB-DBK206 Screw-Terminal Adaptor Board

Similar in function to the OMB-DBK202, but designed for mounting in 19-inch enclosures, the OMB-DBK206 features three vertically mounted straight male DB37 connectors for analog and digital channel expansion (P1 analog I/O, P2 digital I/O, and P3 digital and counter-timer, plus analog output). Two rows of removable screw terminals provide convenient access to all OMB-DAQBOARD-2000 Series I/O-signals (10-22 AWG wire). It mates with the OMB-DAQBOARD-2000 Series via a 1 m (3')

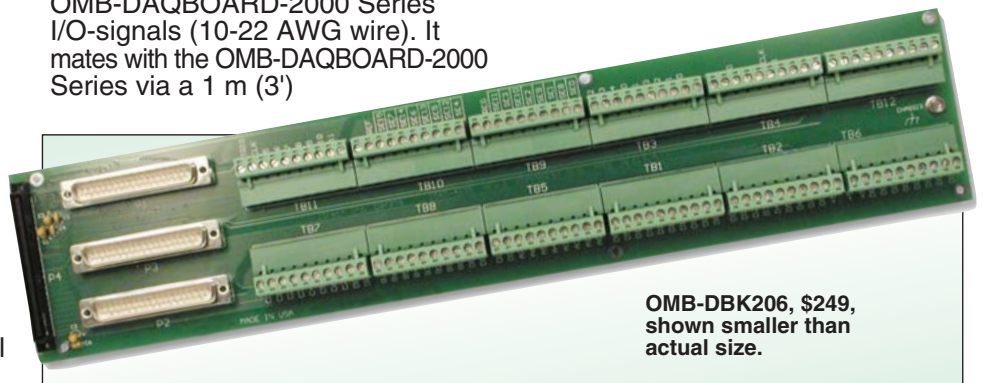

OMB-DBK206, \$249, shown smaller than actual size.



OMB-DBK209, \$59, shown smaller than actual size.



OMB-DBK209, \$59, shown smaller than actual size.

### OMB-DBK201 and OMB-DBK209 Adaptor Boards

For both analog and digital expansion, the OMB-DBK201 adaptor board mates with the OMB-DAQBOARD-2000 Series via a 1 m (3') OMB-CA-195 cable. The OMB-DBK209 provides 3 male DB37 connectors, divided into P1 analog input, P2 digital I/O, and P3 analog output and counter/timer I/O. Each port on the OMB-DBK201 connects to OMB-DBK expansion options via an optional OMB-CA-37-x or OMB-CA-37-xT expansion cable. Alternatively, users can solder wires to the included DB37 female-mating solder-lug connectors, or custom make their own cables that are terminated with a female DB37. An optional 1.8 m (6') cable is available that contains a mating female DB37 connector at one end, and is unterminated at the other end (OMB-CA-113). The OMB-DBK209 is identical in function to the OMB-DBK201 but is snap-track (DIN-rail), and rack-mountable with optional mounting kits.

### OMB-DBK202 and OMB-DBK203 Screw-Terminal Adaptor Board

The OMB-DBK202 screw-terminal board provides convenient screw-terminal access to all signals from the OMB-DAQBOARD-2000 Series. Divided into 3 ports (P1, P2, and P3), the OMB-DBK202 also provides another way to access signals. There are male DB37 connectors on P1 and P2, and an adaptor cable (OMB-CA-60) can be used to connect to the P3 header for connection to DBK signal conditioning and expansion options.



## OMB-DBK208 Multiplexing—Isolated Digital I/O Board

The OMB-DBK208 provides sockets for 16 channels of isolated digital I/O when populated with industry-standard Opto-22 style or compatible solid-state-relay modules. Each socket also features screw terminals and an LED to indicate logic status. The 16 digital I/O can be jumper configured as either inputs or outputs in 8-channel groups.

Multiplexing is built-in, allowing up to 16 OMB-DBK208 boards to be connected to one OMB-DAQBOARD-2000 Series board, for a total signal capacity of 256 isolated digital I/O channels. On-board logic ensures that outputs are disabled during power-up and by a CPU reset. Also included is the ability to choose whether outputs are "off" or in the "last known state" when loss of external power occurs.

The 100-pin P4 connector on the OMB-DBK208 attaches directly to a OMB-DAQBOARD/2000 Series board (via OMB-CA-195 cable), while 2 DB37 connectors permit daisy chaining to other OMB-DBK208 boards and to any of the other OMB-DBK digital boards and modules.

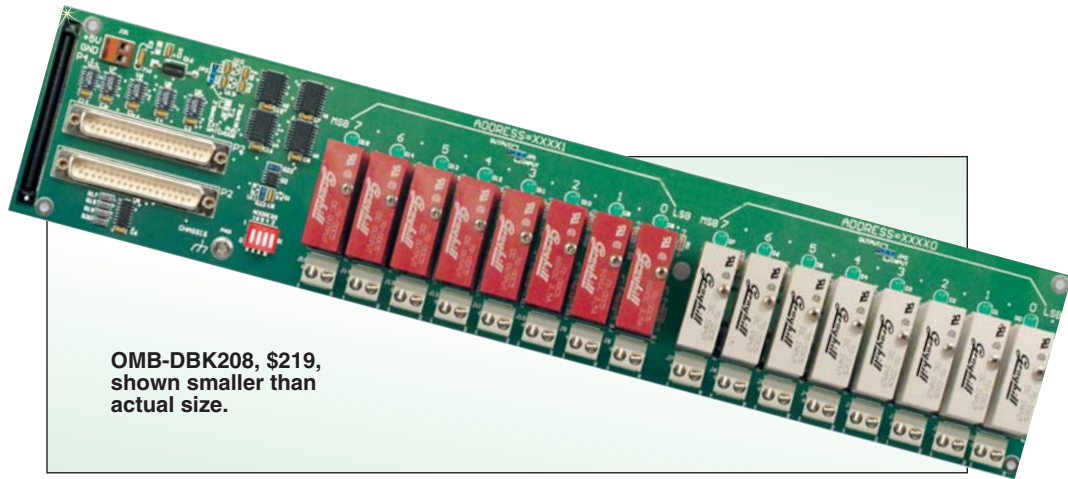

OMB-DBK208, \$219, shown smaller than actual size.

Accuracy** One Year, 0 to 35°C (% Reading + % Range)	
Voltage Range*	Absolute
0 to 10 V	0.015 + 0.005
0 to 5 V	0.015 + 0.005
0 to 2.5 V	0.015 + 0.005
0 to 1.25 V	0.015 + 0.008
0 to 0.625 V	0.015 + 0.008
0 to 0.3125 V	0.015 + 0.008
-10 to 10 V	0.015 + 0.005
-5 to 5 V	0.015 + 0.005
-2.5 to 2.5 V	0.015 + 0.005
-1.25 to 1.25 V	0.015 + 0.005
-0.625 to 0.625 V	0.015 + 0.008
-0.3125 to 0.3125 V	0.015 + 0.008
-0.156 to 0.156 V	0.02 + 0.008

\* Specifications assume differential-input single-channel scan, 200 kHz scan rate, unfiltered.

\*\* Accuracy specification is exclusive of noise.

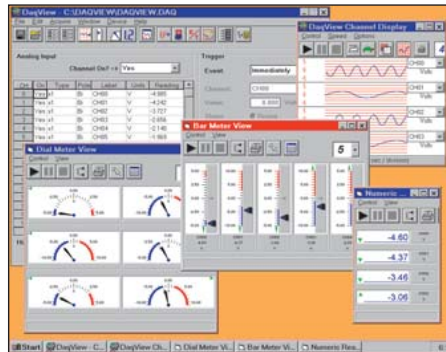

## DAQVIEW Software

The DAQVIEW software allows the user to verify signal connections, acquire and save data to disk, and graphically view real-time data within moments of installing a system. Easily set up all hardware, acquisition, and display parameters without programming, via a simple, spreadsheet-style screen. The software is a full-featured acquisition and display application that provides all the functionality needed for many data logging applications.

## Specifications

### GENERAL (ALL BOARDS)

#### Power Consumption

(per Board): 3.5 W (up to 10 W with external accessories)

#### Power Available for External Signal Conditioning and Expansion Options:

5 V @ 1 A (all boards); ±15 V @ 75 mA each (except for 2002)

#### Operating Temperature:

0 to 60°C (32 to 140°F)

#### Vibration: MIL STD 810E

**Signal I/O Connector:** 100-pin high-density edge-type carries all analog and digital I/O signals

#### Dimensions:

165 W x 15 D x 108 mm H (6.5 x 0.6 x 4.2")

### ANALOG INPUTS

#### (2000, 2001 and 2005) Channels:

16 single-ended or 8 differential, programmable on a per-channel basis as single-ended or differential and unipolar or bipolar

**Expansion:** Up to 256 channels per board (4 boards per PC), without degradation in maximum channel-to-channel scan rate (5 μs/channel)

**Bandwidth:** 500 kHz

**Settling Time:** 5 μs to 1 LSB for full scale step

**Maximum Input Voltage:** ±11 V relative to analog common

**Overvoltage Protection:** ±35 V

**Ranges:** Software or sequencer selectable on a per-channel basis

### A/D SPECIFICATIONS

(2000, 2001 and 2005)

**Type:** Successive approximation

**Resolution:** 16-bit

**Conversion Time:** 5 μs

**Maximum Sample Rate:** 200 kHz

**Non-Linearity (Integral):** ±1 LSB

**Non-Linearity (Differential):**

No missing codes

## INPUT SEQUENCER

(2000, 2001, 2002, 2004 and 2005)

Analog, digital and counter inputs can be scanned synchronously, based on either an internal programmable timer or an external clock source. Analog and digital outputs can be synchronized to either of these clocks.

**Scan Clock Sources:** 2

1. Internal, programmable from 5  $\mu$ s to 5.96 hours in 5  $\mu$ s steps
2. External, TTL-level input up to 200 kHz max

### Programmable Parameters

**per Scan:** Channel (random order), gain, unipolar/bipolar

**Depth:** 512 location

### On-Board Channel-to-Channel

**Scan Rate:** 5 or 10  $\mu$ s per channel, programmable

**Expansion Channel Scan Rate:**

5 or 10  $\mu$ s per channel, programmable

## EXTERNAL ACQUISITION SCAN CLOCK INPUT

(2000, 2001 and 2005)

**Maximum Rate:**

200 kHz

**Clock Signal Range:** 0 to 5 V

**Minimum Pulse Width:**

50 ns high, 50 ns low

## Triggering

**Trigger Sources:** 6, individually selectable for starting and stopping an acquisition. Stop acquisition can occur on a different trigger source than start acquisition, and can be triggered via modes 2, 4, 5 or 6. Pre-trigger is supported with fixed or variable pre-trigger periods.

1. Single-channel analog hardware trigger latency: 5  $\mu$ s max (2000, 2001 and 2005)
2. Single-channel analog software trigger latency: one scan period max (2000, 2001 and 2005)
3. Single-channel digital trigger latency: 5  $\mu$ s max (2000, 2001, 2002, 2004 and 2005)
4. Digital pattern triggering latency: one scan period max (2000, 2001, 2002, 2004 and 2005)
5. Counter/totalizer triggering (2000, 2001, 2002, 2004 and 2005) latency: one scan period, max (all boards)
6. Software triggering (all boards) trigger can be initiated under program control.

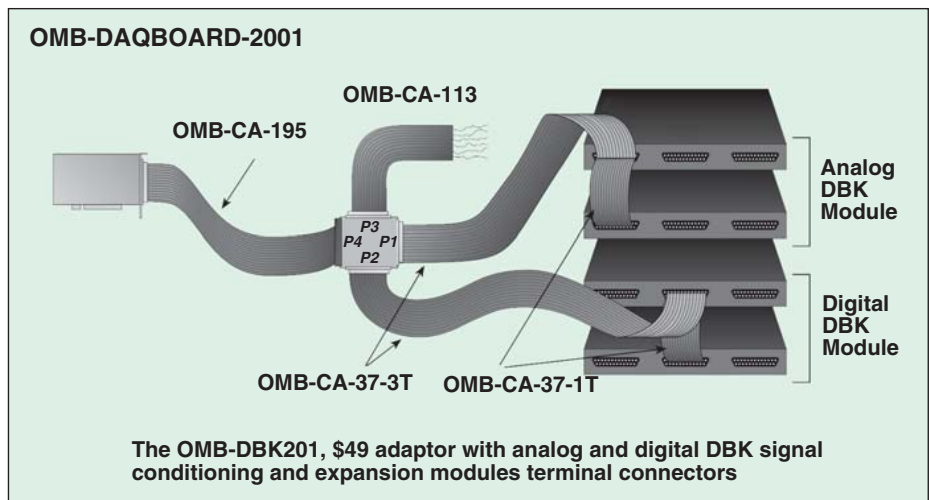

## ANALOG OUTPUTS (2000, 2001 and 2004)

The 2 or 4 analog output channels are updated synchronously relative to scanned inputs, and clocked from either an internal on-board clock or an external clock source. Analog outputs can be updated asynchronously, independent of any other scanning in the system. Bus mastering DMA provides CPU and system-independent data transfers, ensuring accurate outputs independent of other system activities. Streaming from disk or memory is supported, allowing continuous, nearly infinite-length, waveform outputs (limited only by available PC system resources).

**Channels:** 2 (2000); 4 (2001 and 2004)

**Resolution:** 16-bit

**Output Voltage Range:**  $\pm 10$  V

**Clock Sources:** 4, programmable

1. On-board D/A clock, independent of scanning input clock
2. On-board scanning input clock (2000, 2001 & 2004 only)
3. External D/A input clock, independent of external scanning input clock
4. External scanning input clock (2000, 2001 and 2004 only)

## DIGITAL I/O

(2000, 2001, 2002, 2004 and 2005)

**Channels:** 40, expandable up to 208 with OMB-DBK options

**Input Scanning Modes:**

- 2, programmable
1. Asynchronous, under program control at any time
2. Synchronous with input scanning

**Ports:** 3 x 8-bit (82C55 emulation), and 1 x 16-bit; each port is software programmable as input or output

**Input Characteristics:**

100  $\approx$  series, 20 pF to common

**I/O Levels:** TTL

**Sampling/Update Rate:** 200 kHz max

**Output Characteristics:**

Output 12 mA per pin, 200 mA total continuous (per bank of 40 outputs)

## Pattern Generation Output (2000, 2001, 2002, 2004 and 2005)

The P3 16-bit digital I/O port can be configured for 16-bit pattern generation. The pattern can be updated synchronously with an acquisition.

7

## COUNTER

(2000, 2001, 2002, 2004 and 2005)

Counter inputs can be scanned synchronously along with analog and digital scanned inputs, based either on internal programmable timer or an external clock source. Counter can also be read asynchronously.

**Channels:** 4 x 16-bit; cascadable as 2 x 32-bit

**Frequency Measurement Rate:** 10 MHz max

**Trigger Level:** TTL

## FREQUENCY/PULSE GENERATORS

(2000, 2001, 2002, 2004 and 2005)

**Channels:** 2 x 16-bit

**Output:** 1 MHz base rate divided by 1 to 65,535 (programmable)

OMB-DAQBOARD-2001, \$1149, shown smaller than actual size.

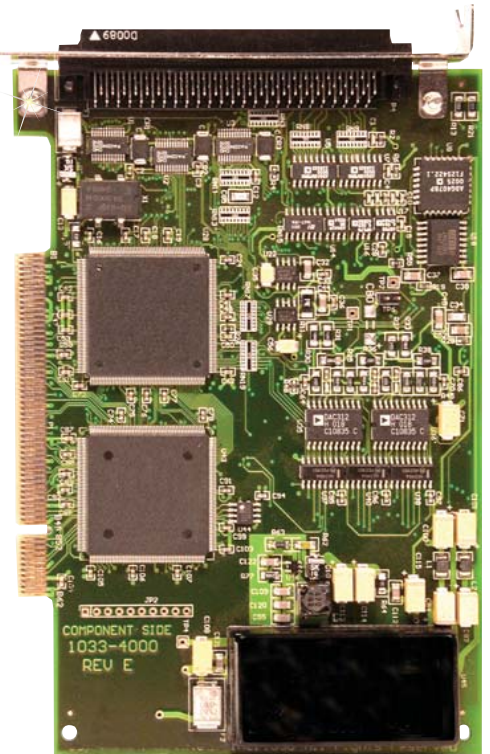
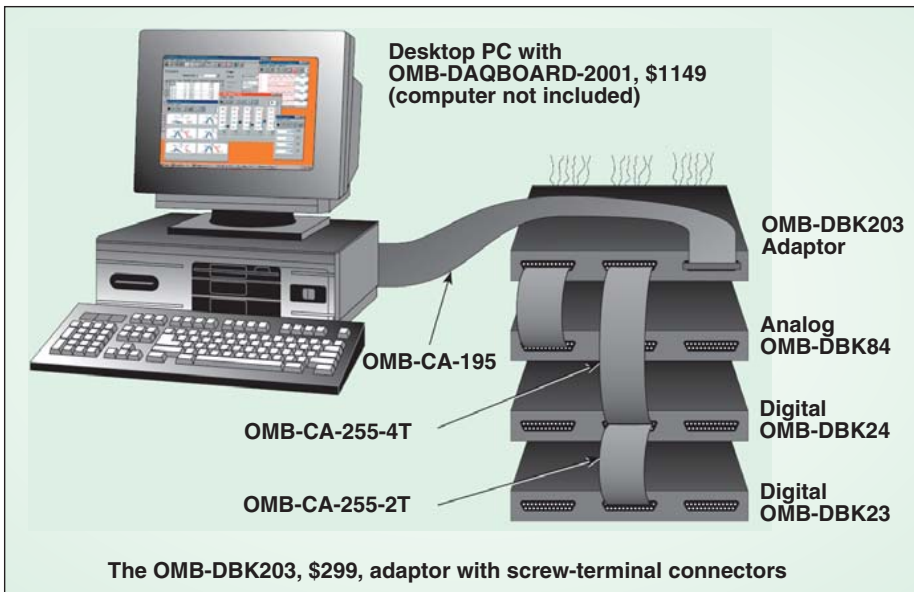

**ALL MODELS AVAILABLE FOR FAST DELIVERY!**

### To Order (Specify Model Number)

Model No.	Price	Description
OMB-DAQBOARD-2001	\$1149	16-bit, 2000 kHz data acquisition board for the PCI-bus with 16 analog inputs, 40 digital I/O, 6 counter/timers, 2 frequency generators and 4 analog waveform outputs
OMB-DAQBOARD-2000	799	Same as OMB-DAQBOARD-2001 but with only 2 analog outputs
OMB-DAQBOARD-2005	689	Same as OMB-DAQBOARD-2001 but with no analog outputs
OMB-DAQBOARD-2004	749	Same as OMB-DAQBOARD-2001 with analog output and digital I/O only (no analog inputs)
OMB-DAQBOARD-2002	349	Same as OMB-DAQBOARD-2001 with digital I/O only (no analog I/O)

### Accessories

Model No.	Price	Description
OMB-DBK200	\$39	Adaptor board for analog I/O (P1 port)
OMB-DBK202	199	Screw terminal adaptor board, P1, P2, P3
OMB-DBK203	299	Screw terminal adaptor board, P1, P2, P3, with enclosure
OMB-DBK206	249	Screw terminal adaptor board
OMB-DBK207	249	Signal conditioning board
OMB-DBK207/CJC	399	Signal conditioning board with CJC
OMB-DBK208	219	Solid state relay board
OMB-DBK209	59	DIN rail-mount adaptor board for P1, P2, P3 ports
OMB-CA-195	79	100-conductor expansion 0.9 m (3') cable
OMB-CA-195-6	89	100-conductor expansion 1.8 m (6') cable

All OMB-DAQBOARD-2000s include a CD-ROM with all documentation, including operator's manual, DaqView Windows Software, DAQX API library for Windows 98/2000/ME/NT for C++, Visual Basic and Delphi, and drivers for LabVIEW, TestPoint and DASyLab.

**Ordering Example:** OMB-DAQBOARD-2001, data acquisition board, OMB-DBK200, adaptor board, OMB-DBK11A\*, screw terminal panel, OMB-CA-195, cable, and OMEGACARE 1-year extended warranty for OMB-DAQBOARD-2001 (adds 1 year to standard 1-year warranty), \$1149 + 39 + 189 + 79 + 114 = \$1570.

\*Refer to section H (signal conditioners) of the OMEGA® Complete Data Acquisition and Computer Interface Handbook and Encyclopedia® for details on all the OMB-DBK expansion options that are available for use with the OMB-DAQBOARD-2000 Series.

# omega.co.uk<sup>®</sup>

Your One-Stop Source for Process Measurement and Control!

Freephone 0800 488 488 | International +44(0) 161 777 6622 | Fax +44(0) 161 777 6622 | Sales@omega.co.uk

[www.omega.co.uk](http://www.omega.co.uk)



#### UNITED STATES

[www.omega.com](http://www.omega.com)

1-800-TC-OMEGA

Stamford, CT.

#### CANADA

[www.omega.ca](http://www.omega.ca)

Laval(Quebec)

1-800-TC-OMEGA

#### GERMANY

[www.omega.de](http://www.omega.de)

Deckenpfronn, Germany

0800-8266342

#### UNITED KINGDOM

[www.omega.co.uk](http://www.omega.co.uk)

Manchester, England

0800-488-488

#### FRANCE

[www.omega.fr](http://www.omega.fr)

088-466-342

#### CZECH REPUBLIC

[www.omegaeng.cz](http://www.omegaeng.cz)

Karviná, Czech Republic

596-311-899

#### BENELUX

[www.omega.nl](http://www.omega.nl)

0800-099-33-44



## More than 100,000 Products Available!

### • Temperature

Calibrators, Connectors, General Test and Measurement Instruments, Handheld Instruments for Temperature Measurement, Ice Point References, Indicating Labels, Crayons, Cements and Lacquers, Infrared Temperature Measurement Instruments, Recorders, Relative Humidity Measurement Instruments, PT100 Probes, PT100 Elements, Temperature & Process Meters, Timers and Counters, Temperature and Process Controllers and Power Switching Devices, Thermistor Elements, Probes and Assemblies, Thermocouples, Thermowells and Head and Well Assemblies, Transmitters, Thermocouple Wire, RTD Probes

### • Flow and Level

Air Velocity Indicators, Doppler Flowmeters, Level Measurement, Magnetic Flowmeters, Mass Flowmeters, Pitot Tubes, Pumps, Rotameters, Turbine and Paddle Wheel Flowmeters, Ultrasonic Flowmeters, Valves, Variable Area Flowmeters, Vortex Shedding Flowmeters

### • pH and Conductivity

Conductivity Instrumentation, Dissolved Oxygen Instrumentation, Environmental Instrumentation, pH Electrodes and Instruments, Water and Soil Analysis Instrumentation

### • Data Acquisition

Auto-Dialers and Alarm Monitoring Systems, Communication Products and Converters, Data Acquisition and Analysis Software, Data Loggers Plug-in Cards, Signal Conditioners, USB, RS232, RS485 and Parallel Port Data Acquisition Systems, Wireless Transmitters and Receivers

### • Pressure, Strain and Force

Displacement Transducers, Dynamic Measurement Force Sensors, Instrumentation for Pressure and Strain Measurements, Load Cells, Pressure Gauges, Pressure Reference Section, Pressure Switches, Pressure Transducers, Proximity Transducers, Regulators, Pressure Transmitters, Strain Gauges, Torque Transducers, Valves

### • Heaters

Band Heaters, Cartridge Heaters, Circulation Heaters, Comfort Heaters, Controllers, Meters and Switching Devices, Flexible Heaters, General Test and Measurement Instruments, Heater Hook-up Wire, Heating Cable Systems, Immersion Heaters, Process Air and Duct, Heaters, Radiant Heaters, Strip Heaters, Tubular Heaters