

25.4 mm (1") DIAMETER STAINLESS STEEL COMPRESSION LOAD CELL

STANDARD AND METRIC MODELS

Compression

0-100 lb to 0-10,000 lb
0-500 to 0-50,000 N

1 Newton = 0.2248 lb
1 daNewton = 10 Newtons
1 lb = 454 g
1 t = 1000 kg = 2204 lb

LC304/LCM304 Series

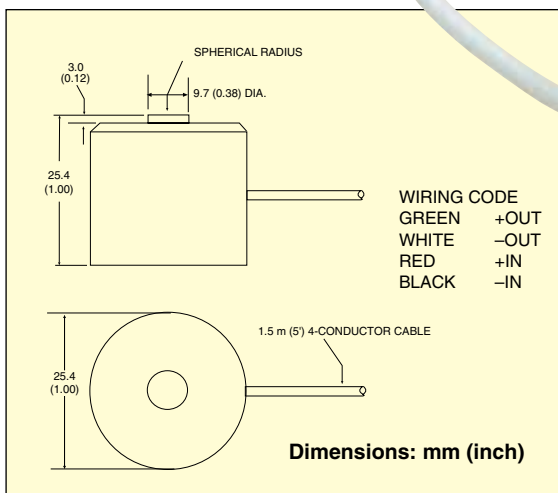

LC304-1K,
shown actual size.

- ✓ Heavy-Duty Design
- ✓ Built-In Load Button for Easy Installation
- ✓ Miniature 25 mm (1") Diameter and 25 mm (1") High Case
- ✓ 5-Point Calibration Provided

OMEGA's LC304/LCM304 Series load cells offer the highest output of all miniature load cells. Their small 25 mm (1") diameter makes it easy to mount them in a pocket or on a flat surface. The rugged stainless steel case and high-quality construction ensure reliability.

SPECIFICATIONS

Excitation: 10 Vdc, 15 Vdc maximum

Output: 2 mV/V nominal

Accuracy: ±0.5% FSO linearity, hysteresis, repeatability combined

5-Point Calibration:

0%, 50%, 100%, 50%, 0%

Zero Balance: ±2% FSO

Operating Temp Range:

-54 to 107°C (-65 to 225°F)

Compensated Temp Range:

16 to 71°C (60 to 160°F)

Deflection: 0.025 to 0.076 mm (0.001 to 0.003")

Thermal Effects:

Zero: 0.009% FSO/°C

Span: 0.036% FSO/°C

Protection Class: IP65

Safe Overload: 150% of capacity

Ultimate Overload: 300% of capacity

Bridge Resistance: 350 Ω minimum

Construction: Stainless steel

Electrical: 1.5 m (5') 4-conductor cable

STANDARD MODELS

To Order Visit omega.com/lc304 for Pricing and Details			
CAPACITY		MODEL NO.	COMPATIBLE METERS
lb	N		
100	445	LC304-100	iSeries, DP41-S, DP25B-S
500	2224	LC304-500	iSeries, DP41-S, DP25B-S
1000	4448	LC304-1K	iSeries, DP41-S, DP25B-S
3000	13,345	LC304-3K	iSeries, DP41-S, DP25B-S
5000	22,242	LC304-5K	iSeries, DP41-S, DP25B-S
7500	33,363	LC304-7.5K	iSeries, DP41-S, DP25B-S
10,000	44,484	LC304-10K	iSeries, DP41-S, DP25B-S

METRIC MODELS

CAPACITY		MODEL NO.	COMPATIBLE METERS
N	lb		
500	112	LCM304-500N	DP41-S, DP25B-S, iSeries
2000	450	LCM304-2KN	DP41-S, DP25B-S, iSeries
5000	1124	LCM304-5KN	DP41-S, DP25B-S, iSeries
10,000	2248	LCM304-10KN	DP41-S, DP25B-S, iSeries
20,000	4496	LCM304-20KN	DP41-S, DP25B-S, iSeries
50,000	11,240	LCM304-50KN	DP41-S, DP25B-S, iSeries

Comes complete with 5-point NIST-traceable calibration and 59 kΩ shunt data.

Ordering Examples: LC304-100, 100 lb capacity load cell.

LC304-5K, 5000 lb capacity load cell.

LCM304-5KN, 5000 N capacity load cell.

omega.co.uk®

Your One-Stop Source for Process Measurement and Control!

Freephone 0800 488 488 | International +44(0) 161 777 6622 | Fax +44(0) 161 777 6622 | Sales@omega.co.uk

www.omega.co.uk



UNITED STATES

www.omega.com

1-800-TC-OMEGA
Stamford, CT.

UNITED KINGDOM

www.omega.co.uk

Manchester, England
0800-488-488
+44-(0)161-777-6611

CANADA

www.omega.ca

Laval(Quebec)
1-800-TC-OMEGA

FRANCE

www.omega.fr

0800-466-342

GERMANY

www.omega.de

Deckenfronn, Germany
0800-8266342

BENELUX

www.omega.nl

0800-099-33-44



More than 100,000 Products Available!

• Temperature

Calibrators, Connectors, General Test and Measurement Instruments, Handheld Instruments for Temperature Measurement, Ice Point References, Indicating Labels, Crayons, Cements and Lacquers, Infrared Temperature Measurement Instruments, Recorders, Relative Humidity Measurement Instruments, PT100 Probes, PT100 Elements, Temperature & Process Meters, Timers and Counters, Temperature and Process Controllers and Power Switching Devices, Thermistor Elements, Probes and Assemblies, Thermocouples, Thermowells and Head and Well Assemblies, Transmitters, Thermocouple Wire, RTD Probes

• Flow and Level

Air Velocity Indicators, Doppler Flowmeters, Level Measurement, Magnetic Flowmeters, Mass Flowmeters, Pitot Tubes, Pumps, Rotameters, Turbine and Paddle Wheel Flowmeters, Ultrasonic Flowmeters, Valves, Variable Area Flowmeters, Vortex Shedding Flowmeters

• pH and Conductivity

Conductivity Instrumentation, Dissolved Oxygen Instrumentation, Environmental Instrumentation, pH Electrodes and Instruments, Water and Soil Analysis Instrumentation

• Data Acquisition

Communication Products and Converters, Data Acquisition and Analysis Software, Data Loggers Plug-in Cards, Signal Conditioners, USB, RS232, RS485, Ethernet and Parallel Port Data Acquisition Systems, Wireless Transmitters and Receivers

• Pressure, Strain and Force

Displacement Transducers, Dynamic Measurement Force Sensors, Instrumentation for Pressure and Strain Measurements, Load Cells, Pressure Gauges, Pressure Reference Section, Pressure Switches, Pressure Transducers, Proximity Transducers, Regulators, Pressure Transmitters, Strain Gauges, Torque Transducers, Valves

• Heaters

Band Heaters, Cartridge Heaters, Circulation Heaters, Comfort Heaters, Controllers, Meters and Switching Devices, Flexible Heaters, General Test and Measurement Instruments, Heater Hook-up Wire, Heating Cable Systems, Immersion Heaters, Process Air and Duct, Heaters, Radiant Heaters, Strip Heaters, Tubular Heaters