

GENERAL PURPOSE 100 MILLIVOLT OUTPUT PRESSURE SENSOR

AVAILABLE IN ABSOLUTE AND GAGE MODELS

PX302/PX312 Series
 15 to 10,000 psi
 1 to 690 Bar



books1.com
 omega.com

Starts at
\$225



MILLIVOLT OUTPUT
 PRESSURE TRANSDUCERS
B



PX312-100GV, \$240, DIN connector included.



PX302-015GV, \$225, shown with DP41-S meter, \$545, and PS-4G snubber, \$10. Shown smaller than actual size.

- ✓ Rugged All Stainless Steel Construction
- ✓ Integral Strain Relief for Cable or DIN Connector
- ✓ High Sensitivity 10 mV/V Output
- ✓ NEMA 3 Enclosure

SPECIFICATIONS

Excitation: 10 Vdc (5 to 15 Vdc limits)
Output: 10 mV/V ratiometric
 100 mV ±1 mV @ 10 Vdc
Accuracy: 0.25% BFS (linearity, hysteresis, repeatability)
Zero Balance: 0 mV ±2 mV
Input Resistance: 15,000 Ω maximum
Long-Term Stability: ±0.5% FS
Typical Life: 100 million cycles
Operating Temperature: -18 to 71°C (0 to 160°F)

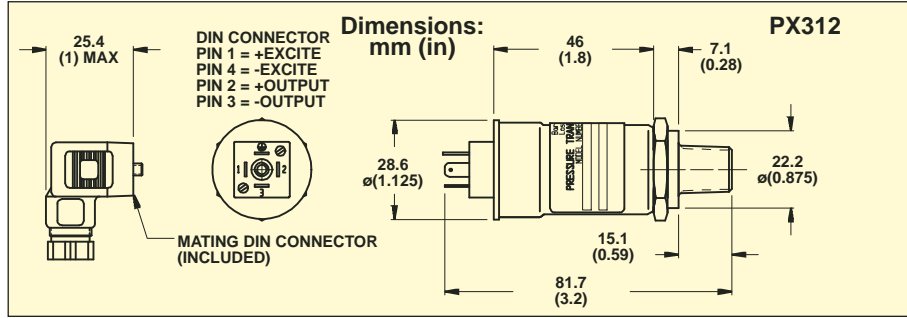
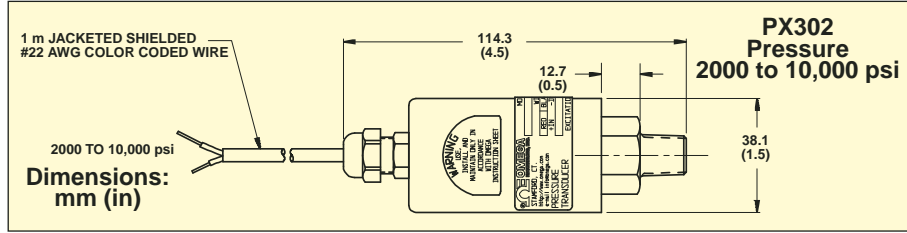
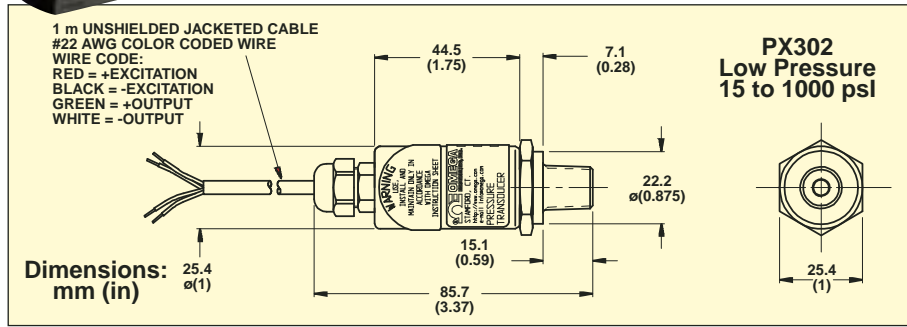

GENERAL PURPOSE PRESSURE SENSOR

Compensated Temperature:
-1 to 71°C (30 to 160°F)
Total Thermal Effects: ±1% FS max
Proof Pressure: 200%, 13,000 psi max
Response Time: 1 ms
Shock: 50 g @ 11 ms
Vibration: 15 g 10 to 2000 Hz
Wetted Parts: 17-4 PH and 300 Series stainless steel
Pressure Port: ¼ NPT male
Electrical Connection:
PX302: 1 m (3') 4-conductor unshielded cable
PX312: Miniature DIN connector (included)
Weight: 131 g (4.6 oz) to 1000 psi
190 g (6.7 oz) from 1000 psi

PX302-015GV, \$225, shown with PS-4G snubber, \$10. Shown approximately actual size.

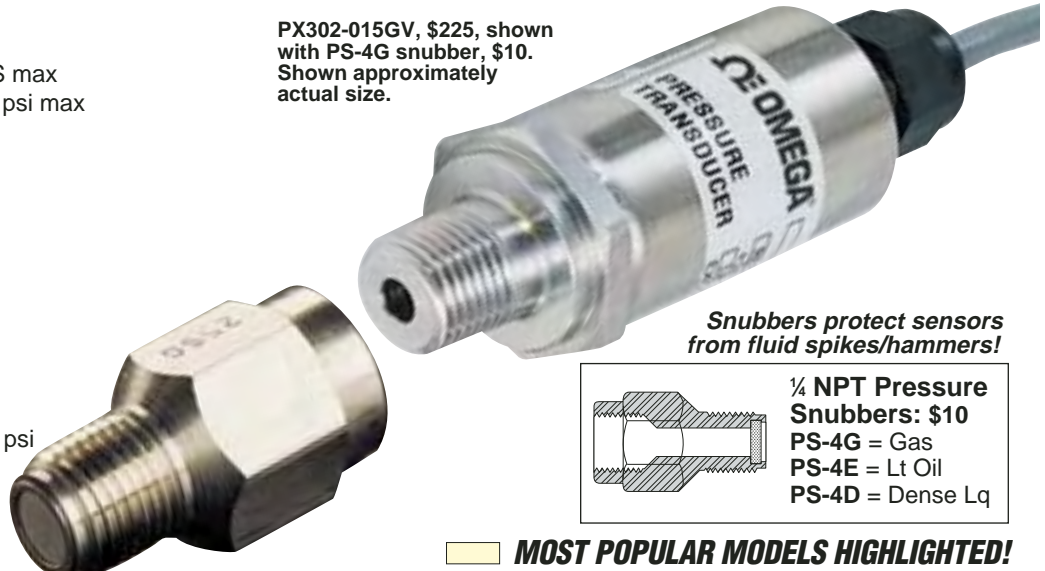

Snubbers protect sensors from fluid spikes/hammers!

¼ NPT Pressure Snubbers: \$10
PS-4G = Gas
PS-4E = Lt Oil
PS-4D = Dense Lq

MOST POPULAR MODELS HIGHLIGHTED!

To Order (Specify Model Number)						
psi	bar	CABLE STYLE	PRICE	CONNECTOR STYLE	PRICE	COMPATIBLE METERS*
GAGE PRESSURE RANGES						
0 to 15	0 to 1.0	PX302-015GV	\$225	PX312-015GV	\$240	DP25B-S, DP41-S, DPiS Series
0 to 30	0 to 2.1	PX302-030GV	225	PX312-030GV	240	DP25B-S, DP41-S, DPiS Series
0 to 50	0 to 3.4	PX302-050GV	225	PX312-050GV	240	DP25B-S, DP41-S, DPiS Series
0 to 100	0 to 6.9	PX302-100GV	225	PX312-100GV	240	DP25B-S, DP41-S, DPiS Series
0 to 200	0 to 13.8	PX302-200GV	225	PX312-200GV	240	DP25B-S, DP41-S, DPiS Series
0 to 300	0 to 20.7	PX302-300GV	225	PX312-300GV	240	DP25B-S, DP41-S, DPiS Series
0 to 500	0 to 34.5	PX302-500GV	225	PX312-500GV	240	DP25B-S, DP41-S, DPiS Series
0 to 1000	0 to 69.0	PX302-1KGV	225	PX312-1KGV	240	DP25B-S, DP41-S, DPiS Series
0 to 2000	0 to 138	PX302-2KGV	225	PX312-2KGV	240	DP25B-S, DP41-S, DPiS Series
0 to 3000	0 to 207	PX302-3KGV	225	PX312-3KGV	240	DP25B-S, DP41-S, DPiS Series
0 to 4000	0 to 276	PX302-4KGV	225	PX312-4KGV	240	DP25B-S, DP41-S, DPiS Series
0 to 5000	0 to 345	PX302-5KGV	225	PX312-5KGV	240	DP25B-S, DP41-S, DPiS Series
0 to 7500	0 to 517	PX302-7.5KGV	225	PX312-7.5KGV	240	DP25B-S, DP41-S, DPiS Series
0 to 10,000	0 to 690	PX302-10KGV	225	PX312-10KGV	240	DP25B-S, DP41-S, DPiS Series
ABSOLUTE PRESSURE RANGES						
0 to 15	0 to 1.0	PX302-015AV	\$225	PX312-015AV	\$240	DP25B-S, DP41-S, DPiS Series
0 to 30	0 to 2.1	PX302-030AV	225	PX312-030AV	240	DP25B-S, DP41-S, DPiS Series
0 to 50	0 to 3.4	PX302-050AV	225	PX312-050AV	240	DP25B-S, DP41-S, DPiS Series
0 to 100	0 to 6.9	PX302-100AV	225	PX312-100AV	240	DP25B-S, DP41-S, DPiS Series
0 to 200	0 to 13.8	PX302-200AV	225	PX312-200AV	240	DP25B-S, DP41-S, DPiS Series
0 to 300	0 to 20.7	PX302-300AV	225	PX312-300AV	240	DP25B-S, DP41-S, DPiS Series

Comes with complete operator's manual. * See section D for compatible meters.

Ordering Example: PX302-050GV, pressure transducer with 50 psig full scale rating and PS-4E pressure snubber for water and light oils, \$225 + 10 = \$235.

ACCESSORIES

MODEL NO.	PRICE	DESCRIPTION
PS-4E	\$10	Pressure snubber for water or light oils
PS-4D	10	Pressure snubber for dense liquids or oils
PS-4G	10	Pressure snubber for gases and steam
MS-1808	\$125	Reference Book: Plant Engineer's Handbook

omega.co.uk[®]

Your One-Stop Source for Process Measurement and Control!

Freephone 0800 488 488 | International +44(0) 161 777 6622 | Fax +44(0) 161 777 6622 | Sales@omega.co.uk

www.omega.co.uk



UNITED STATES

www.omega.com

1-800-TC-OMEGA
Stamford, CT.

UNITED KINGDOM

www.omega.co.uk

Manchester, England
0800-488-488
+44-(0)161-777-6611

CANADA

www.omega.ca

Laval(Quebec)
1-800-TC-OMEGA

FRANCE

www.omega.fr

0800-466-342

GERMANY

www.omega.de

Deckenfronn, Germany
0800-8266342

BENELUX

www.omega.nl

0800-099-33-44



More than 100,000 Products Available!

• Temperature

Calibrators, Connectors, General Test and Measurement Instruments, Handheld Instruments for Temperature Measurement, Ice Point References, Indicating Labels, Crayons, Cements and Lacquers, Infrared Temperature Measurement Instruments, Recorders, Relative Humidity Measurement Instruments, PT100 Probes, PT100 Elements, Temperature & Process Meters, Timers and Counters, Temperature and Process Controllers and Power Switching Devices, Thermistor Elements, Probes and Assemblies, Thermocouples, Thermowells and Head and Well Assemblies, Transmitters, Thermocouple Wire, RTD Probes

• Flow and Level

Air Velocity Indicators, Doppler Flowmeters, Level Measurement, Magnetic Flowmeters, Mass Flowmeters, Pitot Tubes, Pumps, Rotameters, Turbine and Paddle Wheel Flowmeters, Ultrasonic Flowmeters, Valves, Variable Area Flowmeters, Vortex Shedding Flowmeters

• pH and Conductivity

Conductivity Instrumentation, Dissolved Oxygen Instrumentation, Environmental Instrumentation, pH Electrodes and Instruments, Water and Soil Analysis Instrumentation

• Data Acquisition

Communication Products and Converters, Data Acquisition and Analysis Software, Data Loggers Plug-in Cards, Signal Conditioners, USB, RS232, RS485, Ethernet and Parallel Port Data Acquisition Systems, Wireless Transmitters and Receivers

• Pressure, Strain and Force

Displacement Transducers, Dynamic Measurement Force Sensors, Instrumentation for Pressure and Strain Measurements, Load Cells, Pressure Gauges, Pressure Reference Section, Pressure Switches, Pressure Transducers, Proximity Transducers, Regulators, Pressure Transmitters, Strain Gauges, Torque Transducers, Valves

• Heaters

Band Heaters, Cartridge Heaters, Circulation Heaters, Comfort Heaters, Controllers, Meters and Switching Devices, Flexible Heaters, General Test and Measurement Instruments, Heater Hook-up Wire, Heating Cable Systems, Immersion Heaters, Process Air and Duct, Heaters, Radiant Heaters, Strip Heaters, Tubular Heaters