

# COMPACT PRESSURE TRANSDUCERS

## ALL STAINLESS STEEL WETTED PARTS



**PX480A Series**  
 0 to -14.7 to 0-3000 psi  
 0 to -1 to 0-207 bar

Starts at  
**\$195**



PX480A-015GV, \$195,  
 shown larger than actual size.

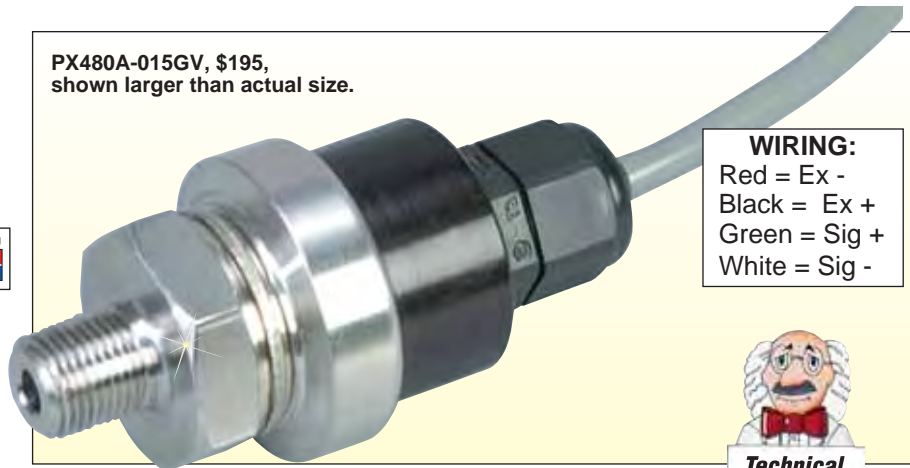

**WIRING:**  
 Red = Ex -  
 Black = Ex +  
 Green = Sig +  
 White = Sig -



- ✓ Excellent Total Accuracy and Interchangeability
- ✓ Gage Pressure, Vacuum, and Compound Ranges Available
- ✓ Rugged, Compact Design
- ✓ RFI/EMI Protection
- ✓ 316L Stainless Steel Wetted Parts

**Wetted Parts:** 316L SS  
**Vibration:** 10 g, 55 to 2000 Hz  
**Shock:** 30 g  
**Process Connection:** 1/8 NPT male

**Electrical Connection:** 0.4 m (18") 24-gage shielded cable  
**Dimensions:** 1 1/2 hex; 72 H x 29.7 mm Dia. (2.84 x 1.17")  
**Weight:** 142 g (5 oz)

**MOST POPULAR MODELS HIGHLIGHTED!**

**To Order (Specify Model Number)**

GAGE PRESSURE RANGES					
psi	bar	MODEL NO.	PRICE	COMPATIBLE METERS*	
0 to 1	0 to 68.9 mbar	PX480A-001GV	\$215	DP25B-S, DP41-S, DPiS Series	
0 to 6	0 to 414 mbar	PX480A-006GV	195	DP25B-S, DP41-S, DPiS Series	
0 to 15	0 to 1.0	PX480A-015GV	195	DP25B-S, DP41-S, DPiS Series	
0 to 30	0 to 2.1	PX480A-030GV	195	DP25B-S, DP41-S, DPiS Series	
0 to 60	0 to 4.1	PX480A-060GV	195	DP25B-S, DP41-S, DPiS Series	
0 to 100	0 to 6.9	PX480A-100GV	195	DP25B-S, DP41-S, DPiS Series	
0 to 200	0 to 13.8	PX480A-200GV	195	DP25B-S, DP41-S, DPiS Series	
0 to 300	0 to 20.7	PX480A-300GV	195	DP25B-S, DP41-S, DPiS Series	
0 to 500	0 to 34.5	PX480A-500GV	195	DP25B-S, DP41-S, DPiS Series	
0 to 1000	0 to 69.0	PX480A-1KSV	265	DP25B-S, DP41-S, DPiS Series	
0 to 2000	0 to 138	PX480A-2KSV	265	DP25B-S, DP41-S, DPiS Series	
0 to 3000	0 to 207	PX480A-3KSV	265	DP25B-S, DP41-S, DPiS Series	
VACUUM AND COMPOUND RANGES					
0 to -14.7	0 to -1.0	PX480A-015VACV	\$195	DP25B-S, DP41-S, DPiS Series	
-14.7 to 15	-1.0 to 1.0	PX480A-015CV	195	DP25B-S, DP41-S, DPiS Series	
-14.7 to 30	-1.0 to 2.1	PX480A-030CV	195	DP25B-S, DP41-S, DPiS Series	
-14.7 to 60	-1.0 to 4.1	PX480A-060CV	195	DP25B-S, DP41-S, DPiS Series	

OMEGA's PX480A Series transducers, designed for general industrial and commercial requirements, offer excellent performance in a wide range of applications. They are based on proven micro-machined silicon technology, providing high reliability, long-term stability, and low cost. They are extremely accurate, with less than 0.3% FS reference accuracy. Wetted parts are made of 316L stainless steel for a wide range of media compatibility.

**SPECIFICATIONS**

- Excitation:** 10 Vdc (regulated)
- Output:** 0 to 50 mV for 0 to 1 psi models, 0 to 100 mV for all other ranges; bridge output
- Load Resistance:** 50,000 Ω minimum
- Accuracy:** 0.3% BFSL maximum (includes linearity, hysteresis and repeatability)
- Operating Temperature:** -40 to 80°C (-40 to 176°F)
- Compensated Temperature:** -25 to 75°C (-13 to 167°F)
- Process Temperature:** -40 to 100°C (-40 to 212°F)
- Thermal Zero Effect:** 2% FS maximum over compensated temperature range
- Thermal Span Effect:** 2% FS maximum over compensated temperature range
- 1-Year Stability:** <0.25% FS
- Proof Pressure:** 2x FS
- Burst Pressure:** 3x FS

**Accessories**

MODEL NO.	PRICE	DESCRIPTION
PS-8E	\$10	Pressure snubber for water or light oils
PS-8D	10	Pressure snubber for dense liquids or oils
PS-8G	10	Pressure snubber for gases and steam
MS-1785	53	Reference Book: Industrial Control Systems

\* See section D for compatible meters.  
 Comes with complete operator's manual.  
**Ordering Example:** PX480A-100GV, 0 to 100 psig transducer with 1 to 100 mV output, \$195.

MILLIVOLT OUTPUT PRESSURE TRANSDUCERS B

# omega.co.uk<sup>®</sup>

Your One-Stop Source for Process Measurement and Control!

Freephone 0800 488 488 | International +44(0) 161 777 6622 | Fax +44(0) 161 777 6622 | Sales@omega.co.uk

[www.omega.co.uk](http://www.omega.co.uk)



#### UNITED STATES

[www.omega.com](http://www.omega.com)

1-800-TC-OMEGA  
Stamford, CT.

#### UNITED KINGDOM

[www.omega.co.uk](http://www.omega.co.uk)

Manchester, England  
0800-488-488  
+44-(0)161-777-6611

#### CANADA

[www.omega.ca](http://www.omega.ca)

Laval(Quebec)  
1-800-TC-OMEGA

#### FRANCE

[www.omega.fr](http://www.omega.fr)

0800-466-342

#### GERMANY

[www.omega.de](http://www.omega.de)

Deckenfronn, Germany  
0800-8266342

#### BENELUX

[www.omega.nl](http://www.omega.nl)

0800-099-33-44



## More than 100,000 Products Available!

### • Temperature

Calibrators, Connectors, General Test and Measurement Instruments, Handheld Instruments for Temperature Measurement, Ice Point References, Indicating Labels, Crayons, Cements and Lacquers, Infrared Temperature Measurement Instruments, Recorders, Relative Humidity Measurement Instruments, PT100 Probes, PT100 Elements, Temperature & Process Meters, Timers and Counters, Temperature and Process Controllers and Power Switching Devices, Thermistor Elements, Probes and Assemblies, Thermocouples, Thermowells and Head and Well Assemblies, Transmitters, Thermocouple Wire, RTD Probes

### • Flow and Level

Air Velocity Indicators, Doppler Flowmeters, Level Measurement, Magnetic Flowmeters, Mass Flowmeters, Pitot Tubes, Pumps, Rotameters, Turbine and Paddle Wheel Flowmeters, Ultrasonic Flowmeters, Valves, Variable Area Flowmeters, Vortex Shedding Flowmeters

### • pH and Conductivity

Conductivity Instrumentation, Dissolved Oxygen Instrumentation, Environmental Instrumentation, pH Electrodes and Instruments, Water and Soil Analysis Instrumentation

### • Data Acquisition

Communication Products and Converters, Data Acquisition and Analysis Software, Data Loggers Plug-in Cards, Signal Conditioners, USB, RS232, RS485, Ethernet and Parallel Port Data Acquisition Systems, Wireless Transmitters and Receivers

### • Pressure, Strain and Force

Displacement Transducers, Dynamic Measurement Force Sensors, Instrumentation for Pressure and Strain Measurements, Load Cells, Pressure Gauges, Pressure Reference Section, Pressure Switches, Pressure Transducers, Proximity Transducers, Regulators, Pressure Transmitters, Strain Gauges, Torque Transducers, Valves

### • Heaters

Band Heaters, Cartridge Heaters, Circulation Heaters, Comfort Heaters, Controllers, Meters and Switching Devices, Flexible Heaters, General Test and Measurement Instruments, Heater Hook-up Wire, Heating Cable Systems, Immersion Heaters, Process Air and Duct, Heaters, Radiant Heaters, Strip Heaters, Tubular Heaters