



100 and 180 mm Programmable Chart Recorders

RD101B Series
Starts at
\$1615



- ✓ Digital and Bar Graph Display
- ✓ 1, 2, 3, 4 Continuous Pens or 6-Point Dot Printing Models (RD1800B Also Has 12, 18, 24-Dot Printing)
- ✓ Universal Inputs: Thermocouple, RTD, Voltage
- ✓ Programmable Input Types, Full Scale Ranges, Alarms, Chart Speed
- ✓ Powerful but Easy to Use
- ✓ Interactive Displays Make Setup Easy
- ✓ Large, Bright Dot-Matrix Display for Data and Units
- ✓ Compact—Only 220 mm (8.6") Deep
- ✓ Splashproof Front Door
- ✓ Fast Dot Printing—6 Channels in as Little as 10 Seconds
- ✓ Removable Terminal Blocks for Easy Wiring
- ✓ Optional Alarms with Remote Control
- ✓ Optional RS422A/485 or Ethernet Communications
- ✓ Pen Offset Compensation

The RD100B 100 mm (4") and RD1800B 180 mm (7") Series programmable chart recorders are easy to use. They feature universal thermocouple, RTD, and DC voltage (mV or V) inputs, as well as an analog bar graph and a digital display.



RD106B, \$2420, with KTSS-18G-12, \$19 thermocouple, sold separately, shown smaller than actual size. See page A-73.

Each recorder can print out—at programmed intervals or on demand—the date and time, channel number, scale marking, tag number, proper engineering units, chart speed, alarm value, and complete program list.

The non-contact, ultrasonic pen-position transducer is more accurate than standard pen mechanisms. The wear-free, brushless DC servo-motor eliminates the need for motor brushes, lead wire, and connectors, and is directly mounted to the printed circuit board. These 2 features contribute to the long, trouble-free life of these recorders.

Optional Communication Output
The optional RS422A/485 or Ethernet interface lets the user

connect up to 32 units on a multidrop line to a single host computer for data logging or input/output of any setup parameter.

Versatile Alarm and Remote Control Functions (Optional)

The user can select up to 4 of the following 6 alarm types: high/low limit, deviation high/low limit, rate of change high/low. Optional alarm relay contact outputs are front-panel selectable. Also included is a remote control feature, which lets the user select any 5 of the following functions through the front keypad: recording start/stop; chart speed change; manual printout start; message printout start (up to 5 user-defined messages).

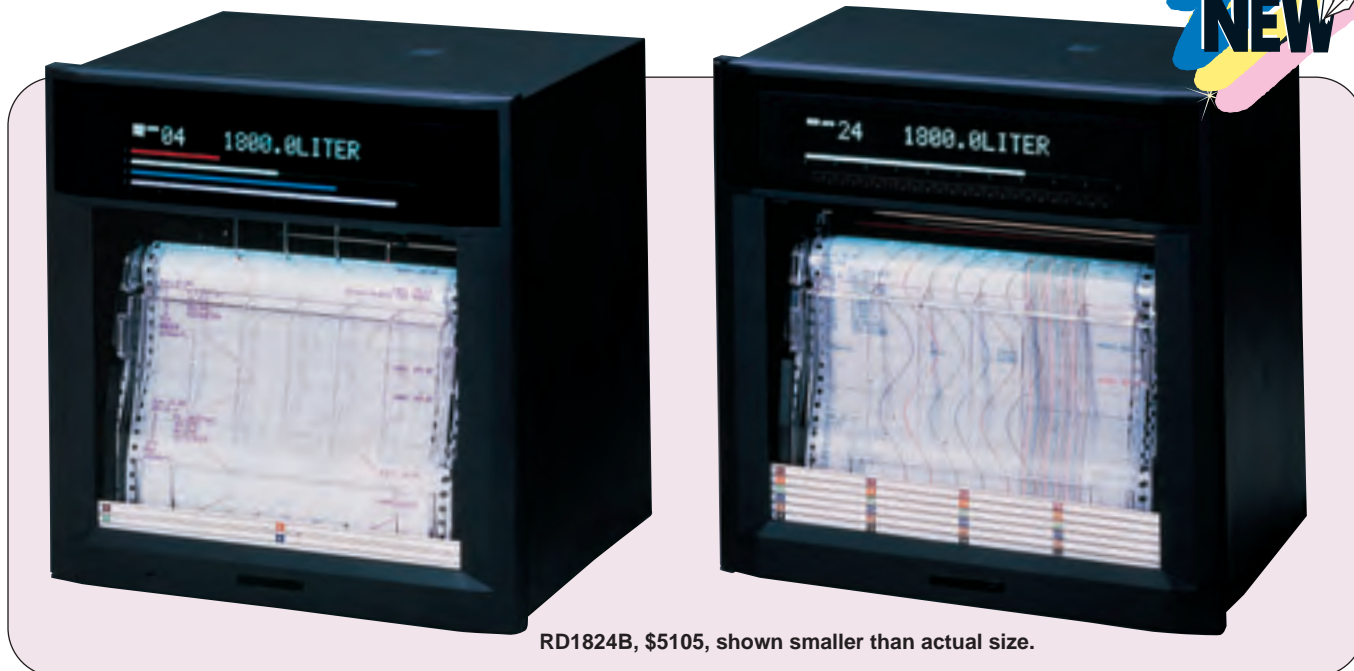

RD1824B, \$5105, shown smaller than actual size.

Specifications

Input	Type*	Measurement Range	Measurement Accuracy	Resolution
T/C	J	-200 to 1100°C (-328 to 2012°F)	±0.15% rdg + 0.5°C (0.9°F); -200 to -100°C (-328 to -148°F): ±0.15% rdg + 0.7°C (1.3°F)	0.1°C
	T	-200 to 400°C (-328 to 752°F)	±0.15% rdg + 0.5°C (0.9°F)	0.1°C
	K	-200 to 1370°C (-328 to 2498°F)	±0.15% rdg + 0.7°C (1.3°F); -200 to -100°C (-328 to -148°F): ±0.15% rdg + 1.0°C (1.8°F)	0.1°C
	E	-200 to 800°C (-328 to 1472°F)	±0.15% rdg + 0.5°C (0.9°F)	0.1°C
	N	0 to 1300°C (32 to 2372°F)	±0.15% rdg + 0.7°C (1.3°F)	0.1°C
	R/S	0 to 1760°C (32 to 3200°F)	±0.15% rdg + 0.1°C (0.2°F); 0 to 100°C (32 to 212°F) ±3.7°C (6.7°F) and 100 to 300°C (212 to 572°F) ±1.5°C (2.7°F)	0.1°C
	B	0 to 1820°C (32 to 3308°F)	±0.15% rdg + 0.1°C above 600°C (0.18°F above 1112°F) 400 to 600°C (752 to 1112°F): ±2.0°C (3.6°F), not specified below 400°C (752°F)	0.1°C
	C(W)	0 to 2315°C (32 to 4199°F)	±0.15% of rdg + 1.0°C (1.8°F)	0.1°C
	J DIN(L)	-200 to 900°C (-328 to 1652°F)	±0.15% rdg + 0.5°C (0.9°F); -200 to -100°C (-328 to -148°F): ±0.15% rdg + 0.7°C (1.3°F)	0.1°C
	T DIN(U)	-200 to 400°C (-328 to 752°F)	±0.15% rdg + 0.5°C (0.9°F)	0.1°C
Vdc	20 mV	-20 to 20 mV	±0.1% rdg + 3-digits	10 µV
	60 mV	-60 to 60 mV	±0.1% rdg + 2-digits	10 µV
	200 mV	-200 to 200 mV	±0.1% rdg + 2-digits	100 µV
	2V	-20 to 20V	±0.1% rdg + 3-digits	1 mV
	6V	-60 to 60V	±0.1% rdg + 3-digits	1 mV
	20V	-20 to 20V	±0.1% rdg + 2-digits	10 mV
	50V	-50 to 50V	±0.1% rdg + 3-digits	10 mV
	1 to 5V	1 to 5V	±0.1% rdg + 2-digits	1 mV
RTD	Pt100	-200 to 600°C (-328 to 1112°F)	±0.15% rdg + 0.3°C (0.5°F)	0.1°C
	JPt100	-200 to 550°C (-328 to 1022°F)	±0.15% rdg + 0.3°C (0.5°F)	0.1°C
Input	Range		Measurement	Limit
Digital input (operation recording)	Input only		Less than 2.4V: off; 2.4 or more: on (TTL)	Contact inputs; contact on/off

* Note: Thermocouple Type J, K, T, E, R, S, B: ANSI, IEC 584, DIN IEC 584, JIS C 1602-1981; Type N: nicrosil-nisil, IEC 584, DIN IEC 584; Type C W5%-R/W-26%; J DIN, T DIN: DIN 43760.
Pt100: JIS C 1604-1989, JIS C 1606-1989, IEC 751, DIN IEC 751.
JPt100 JIS C 1604-1981, JIS C 1606-1989.



General Specifications

Dimensions:

RD1800B: 288 W x 288 H x 220 mm D
(11.4 x 11.4 x 8.66")

RD100B: 144 W x 144 H x 220 mm D
(5.67 x 5.67 x 8.66")

Weight:

RD1800B: 6 dot, 8.4 kg (20 lb);

24 dot, 9.0 kg (20 lb) approx

RD100B: 1 pen, 2.1 kg (4.5 lb);

2 pen, 3.4 kg (7.5 lb); 3 pen, 3.6 kg

(7.9 lb); 4 pen, 2.4 kg (6.9 lb);

6 dot, 2.5 kg (5.5 lb) approx

Case: Drawn steel

Front Door: Aluminum die casting

Panel Thickness:

2 x 26 mm (0.078 x 1.02")

Power: 90 to 132, 180 to 250 Vac,
50/60 Hz standard

Maximum Power Consumption:

Approximately 40 VA

Ambient Temperature

and Humidity: 0 to 50°C (32 to 122°F),
20 to 80% RH @ 5 to 40°C (41 to 104°F)

Memory Backup: Lithium battery

Input

Reference Junction Accuracy:

Type J, K, T, E, N, J DIN, T DIN: $\pm 0.5^\circ\text{C}$;
Type R, S, B, C: $\pm 1^\circ\text{C}$

Temperature Coefficients:

Effect of ambient temperature
of 10°C (50°F)

Digital Display:

Within $\pm 0.1\%$ rdg + 1 digit

Recording: Within digital
display $\pm 0.2\%$ of recording span
(excluding reference junction)

Performance Under Reference Operating Conditions:

Temperature:

23 $\pm 2^\circ\text{C}$ (73 $\pm 3.6^\circ\text{F}$)

Humidity: 55 $\pm 10\%$

Usable Power Voltage: 90 to 132 or
180 to 264 Vac, 50/60 Hz

Warm-Up Time: 30 minutes

Measurement Intervals:

Pen Models: 125 ms/channel

Dot Models:

RD100B: 1 s/6 channels;

RD1800B: 2.5 s/6 channels

Input Resistance: DC voltage 200 mV
and lower ranges; T/C ranges: 10 M Ω
min; DC voltage 2V and higher ranges:
approx 1 M Ω

Input Bias Current: 10 nA max (approx.
100 nA on a T/C input if burnout detection
selected)

Thermocouple Burnout Detection:

On/off programmable for each channel or
more detected as open circuit

1 to 5 V Burnout: Less than 0.2V

Maximum Input Voltage: 200 mV or
lower and TC, RTS, DI ranges: ± 10 Vdc
continuous; 2 Vdc or greater:
 ± 6 Vdc continuous

Recording System

Recording Span:

RD100B: 100 mm

RD1800B: 180 mm

Pen-Writing: Disposable felt pens (analog
recording), plotter pens
(digital recording)

Dot Printing:

6-color wire dot recording

Recording Paper:

RD1800: 20 m Z-fold chart

RD100B: 16 m Z-fold chart

Step Response Time:

RD1800: 1.5 s

RD100B: 1 s max

Deadband:

Pen models
0.2% of recording span max

Maximum Recording

Resolution: Dot-printing models 0.1 mm

Recording Format:

Normal, zone and partial recording

Chart Speed:

Pen Models: 5 to 12,000 mm/h
(82 increments)

Dot-Printing Models: 1 to 1500 mm/h
(1 mm steps)

Analog Recording Cycles:

Pen Models: Continuous

Dot Printing Models: 6 dots/10 s;
12 dots/15 s; 18 dots/20 s,
24 dots/30 s max

Print Cycle Time—Dot Printing

Models: Auto mode chart speed
determines analog recording cycle rate;
fix mode recording is done at fastest
analog recording interval

Chart Speed Accuracy: Less than
 $\pm 0.1\%$ (chart running more than
1000 mm continuously and related
to grid of the paper)

Message Printout:

5 messages, date/time and message up
to 16 characters

Periodic Printout: Engineering units (up
to 6 alphanumeric), tag marker
(up to 7 alphanumeric), scale marker
(0/100%), the measured data print

List Printout:

Prints listing of range settings, alarm
settings and other parameters

Manual Printout: Provides a digital
printout of measured results

Display System

Display:

RD100B: VFD 254 x 406 mm
(10 x 16") dot matrix

RD1800B: 457 x 406 mm
(18 x 16") dot matrix

Display: Selectable display screen

Bar Graph Display: Measured value is
1% resolution, left-reference or
center-zero bar graph display (individually
programmable for each channel)

Alarms:

Display: Alarm setting level indicator;
channel number (dot-matrix
models only)

Levels: 4 levels/channel

Types: High, low, high rate of
change, low rate of change, delta
high, delta low (rate of change
alarm time interval: measurement
interval x 1 to 15)

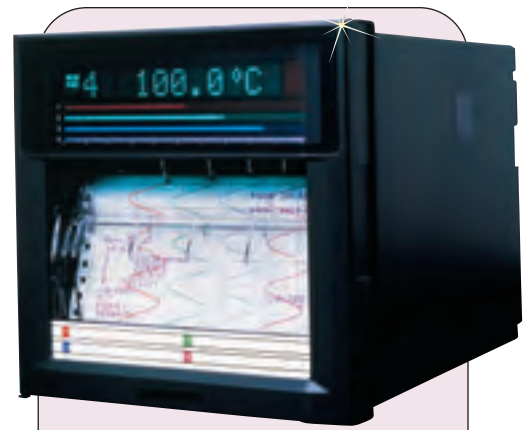

**RD1804B, \$5275, shown
smaller than actual size.**

Indications: Shared alarm indicator
flashes; in dot-printing models, alarm
status of alarm channel is
also displayed

Recording: Prints channel number,
alarm type and time on or off on right
side of chart

Optional Alarm Relay Contact Output and Remote Control

Alarm Relays: 2, 4, 6 (all units),
12 and 24 points (RD1800 only);
outputs programmable; energize or
de-energize (all relays); hold or non-hold

Remote Control: Enables any mix of the
following to be assigned to 5 contact
inputs: output programmable, recording
start/stop; chart speed change; manual
printout start; alarm acknowledge, time
adjust; computation start/stop,
computation restate; message printout
start (up to 5)

Input Signal:

TTL, open collector, contact

Input Signal Width: 1 second minimum

Contact Capacity: 3 A @ 250 Vac;
0.1 A @ 250 Vdc resistive load

Optional Communication Output

RS422A/485: Conforms to EIA RS422A;
can be used to output measured values,
input and output setup parameters

Addresses: 1 to 32

Asynchronous:

Start-stop synchronization

Communication System: Half duplex

Wiring: 5-wire

Data Length: 7 or 8-bit

Parity: odd, even or none

Communication Rate: 1200, 2400,
4800, 9600, 19,200, 38,400 baud

Communication Mode:

ASCII or binary (measured data only)

Communication Distance: 1.2 km

Ethernet Interface: Electrical and
mechanical conformance to IEEE8023

Transmission Media: 10 Base-T

Protocol: TCP, IP, UDP, ICMP, ARP

CE Option: Meets European
standards for EMI interference



☐ **MOST POPULAR MODELS HIGHLIGHTED!**

To Order (Specify Model Number)

Model No.	Price	Input Channels	Recording Type
RD101B	\$1615	1	100 mm (4") continuous
RD102B	1995	2	100 mm (4") continuous
RD103B	2650	3	100 mm (4") continuous
RD104B	3170	4	100 mm (4") continuous
RD106B	2420	6	100 mm (4") dot
RD1801B	2220	1	180 mm (7") continuous
RD1802B	3010	2	180 mm (7") continuous
RD1803B	3800	3	180 mm (7") continuous
RD1804B	5275	4	180 mm (7") continuous
RD1806B	3215	6	180 mm (7") dot
RD1812B	3795	12	180 mm (7") dot
RD1818B	4455	18	180 mm (7") dot
RD1824B	5105	24	180 mm (7") dot

Each unit comes complete with 1 pen per channel, 1 pack of paper, mounting brackets and operator's manual.

Ordering Example: RD104B, 4-pen recorder with 4-alarm relays, \$3170.

OCW-3, OMEGACARESM extends standard 2-year warranty to a total of 5 years (\$350), \$3170 + 350 = \$3520.

Options (Not Field Installable)

Suffix No.	Price	Description
/A1/R1	\$330	2-alarm outputs, remote control
/A2/R1	485	4-alarm outputs, remote control (RD100A Series only)
/A3/R1	620	6-alarm outputs, remote control (RD106A and RD1800 Series)
/A4/R1	1010	12-alarm outputs, remote control (RD1806, RD1812, RD1818, RD1824 only)
/A5/R1	1600	24-alarm outputs, remote control (RD1824 only)
/C3	205	RS422A communications
24V	165	24 Vdc power (not available on portable unit)
/C7	205	Ethernet interface, 10 Base-T

Accessories

Model No.	Price	Description
RD100A-01	\$18	Disposable red felt pen channel-1
RD100A-02	18	Disposable green felt pen channel-2
RD100A-03	18	Disposable blue felt pen channel-3
RD100A-04	18	Disposable violet felt pen channel-4
RD100A-11	16	Plotter pen
RD100B-SW1	150	Configuration software for models with communication interface
RD100B-SW2	260	Configuration software for models without communication interface
RD100-RC	27	6-color print ribbon purple, red, green, blue, brown, black (RD106 only)
RD110-RC	46	6-color print ribbon for RD1806, RD1812, RD1818 and RD1824
RD100-ZFP-1	10	Z-fold chart paper (pkg of 1) 100 mm x 16 m (4" x 52') RD100A Series
RD110-ZFP	14	Z-fold chart paper (pkg of 1) 180 mm x 20 m (7" x 65') RD1800 Series

Recommended Reference Book: Maynard's Industrial Engineering Handbook, MS-1401, \$150. See Section Y for Additional Books



RD100B Panel Cutout

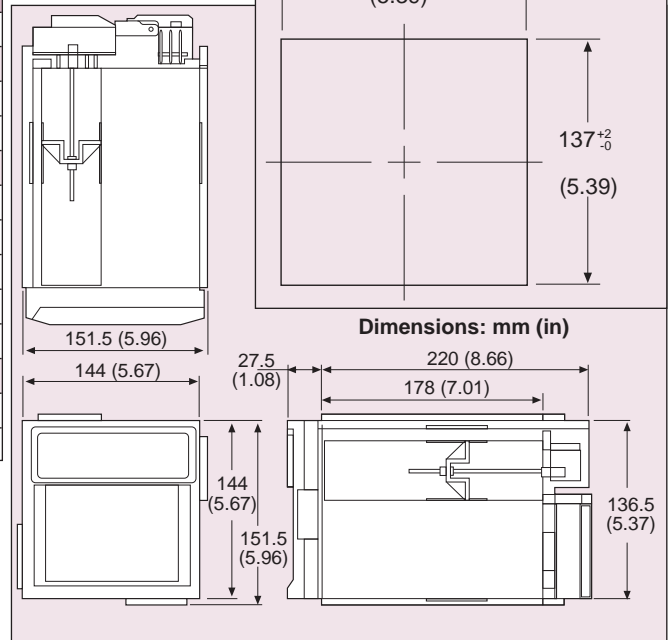

OMEGACARESM extended warranty program is available for models shown on this page.

OMEGACARESM covers parts, labor and equivalent loaners. Ask your sales representative for full details when placing an order.

RD1800B Panel Cutout

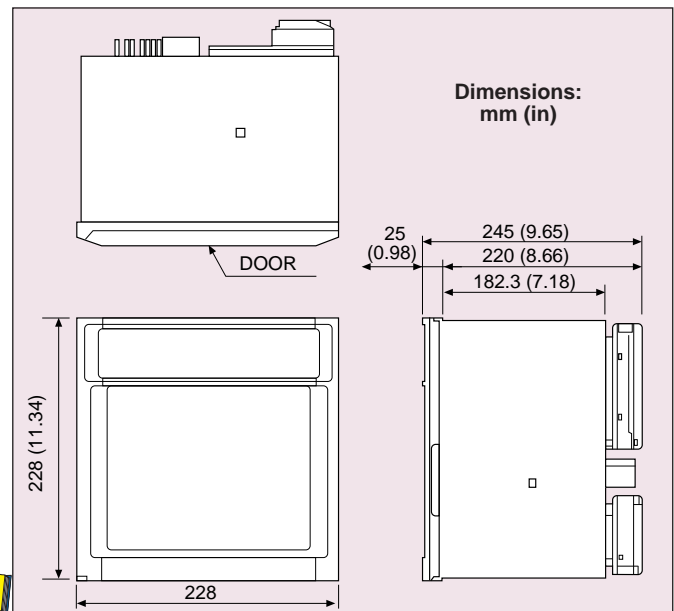
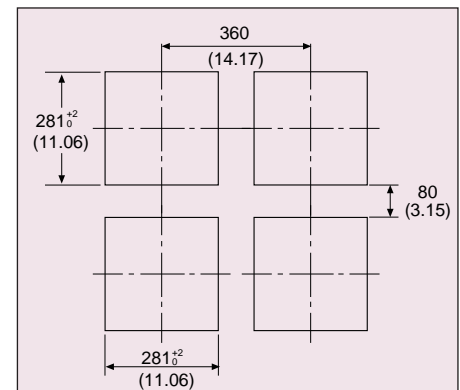

omega.co.uk[®]

Your One-Stop Source for Process Measurement and Control!

Freephone 0800 488 488 | International +44(0) 161 777 6622 | Fax +44(0) 161 777 6622 | Sales@omega.co.uk

www.omega.co.uk



UNITED STATES

www.omega.com

1-800-TC-OMEGA
Stamford, CT.

UNITED KINGDOM

www.omega.co.uk

Manchester, England
0800-488-488
+44-(0)161-777-6611

CANADA

www.omega.ca

Laval(Quebec)
1-800-TC-OMEGA

FRANCE

www.omega.fr

0800-466-342

GERMANY

www.omega.de

Deckenfronn, Germany
0800-8266342

BENELUX

www.omega.nl

0800-099-33-44



More than 100,000 Products Available!

• Temperature

Calibrators, Connectors, General Test and Measurement Instruments, Handheld Instruments for Temperature Measurement, Ice Point References, Indicating Labels, Crayons, Cements and Lacquers, Infrared Temperature Measurement Instruments, Recorders, Relative Humidity Measurement Instruments, PT100 Probes, PT100 Elements, Temperature & Process Meters, Timers and Counters, Temperature and Process Controllers and Power Switching Devices, Thermistor Elements, Probes and Assemblies, Thermocouples, Thermowells and Head and Well Assemblies, Transmitters, Thermocouple Wire, RTD Probes

• Flow and Level

Air Velocity Indicators, Doppler Flowmeters, Level Measurement, Magnetic Flowmeters, Mass Flowmeters, Pitot Tubes, Pumps, Rotameters, Turbine and Paddle Wheel Flowmeters, Ultrasonic Flowmeters, Valves, Variable Area Flowmeters, Vortex Shedding Flowmeters

• pH and Conductivity

Conductivity Instrumentation, Dissolved Oxygen Instrumentation, Environmental Instrumentation, pH Electrodes and Instruments, Water and Soil Analysis Instrumentation

• Data Acquisition

Communication Products and Converters, Data Acquisition and Analysis Software, Data Loggers Plug-in Cards, Signal Conditioners, USB, RS232, RS485, Ethernet and Parallel Port Data Acquisition Systems, Wireless Transmitters and Receivers

• Pressure, Strain and Force

Displacement Transducers, Dynamic Measurement Force Sensors, Instrumentation for Pressure and Strain Measurements, Load Cells, Pressure Gauges, Pressure Reference Section, Pressure Switches, Pressure Transducers, Proximity Transducers, Regulators, Pressure Transmitters, Strain Gauges, Torque Transducers, Valves

• Heaters

Band Heaters, Cartridge Heaters, Circulation Heaters, Comfort Heaters, Controllers, Meters and Switching Devices, Flexible Heaters, General Test and Measurement Instruments, Heater Hook-up Wire, Heating Cable Systems, Immersion Heaters, Process Air and Duct, Heaters, Radiant Heaters, Strip Heaters, Tubular Heaters